

**Models AM-48 and AM-48E  
Personal Transmission  
Test Set**

**INSTRUCTION MANUAL**

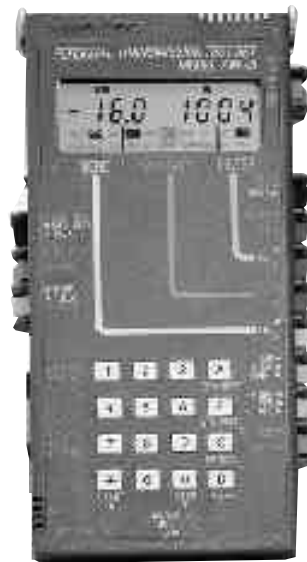

**Ameritec**  
CORPORATION

---

---

**Models AM-48 and AM-48E  
Personal Transmission  
Test Set**

**Instruction Manual**

February 4, 2000

Technical Data Subject to  
Change without Notice

**Ameritec**  
CORPORATION

760 Arrow Grand Circle  
Covina, CA 91722 USA  
TEL 626.915.5441  
FAX 626.915.7181  
[www.ameritec.com](http://www.ameritec.com)

For extra copies of  
this manual, order  
Part No. 18-0015

### Record of Revisions

A	September 1992	Initial Release.
B	January 28, 1998	Minor Update Changes.
C	October 2, 1998	Changed Generator Accuracy Specs.
C1	October 9, 1999	Changed Distortion specification on 1-6.
D	February 4, 2000	Reformatted Manual to provide new soft copy.

## Table of Contents

<b>1. INTRODUCTION .....</b>	<b>1-1</b>
1.1 Manual Overview.....	1-1
1.2 General Description.....	1-2
1.3 AM-48 Technical Specifications.....	1-4
1.4 AM-48E Technical Specifications.....	1-11
<b>2. RECEIVING AND UNPACKING.....</b>	<b>2-1</b>
2.1 Introduction.....	2-1
2.2 Inspection when Received .....	2-1
2.3 Verification of Contents .....	2-1
<b>3. PHYSICAL &amp; FUNCTIONAL DESCRIPTION.....</b>	<b>3-1</b>
3.1 Introduction.....	3-1
3.2 General .....	3-1
3.3 Component Location.....	3-2
3.4 Connectors and Cables.....	3-3
3.5 Switches.....	3-5
3.6 Keyboard.....	3-14
3.7 Display .....	3-17
3.8 Microphone/Speaker.....	3-19
3.9 Hand-Held Printer.....	3-20
3.10 Impedance Adapter.....	3-24
<b>4. POWER CONSIDERATIONS.....</b>	<b>4-1</b>
4.1 General .....	4-1
4.2 Battery Compartment .....	4-1
4.3 Battery-Selector Switch.....	4-1
4.4 Battery Installation .....	4-3
4.5 Battery Information .....	4-3
4.6 AC Power.....	4-4
4.7 Power On/Off Switch.....	4-4

**Table of Contents (18-0015) AM-48 Test Set**

**5. SELF-TEST INSTRUCTIONS..... 5-1**

- 5.1 General ..... 5-1
- 5.2 Self-Test Setup..... 5-1
- 5.3 Quiet Send Mode..... 5-4
- 5.4 Send 1004 Hz..... 5-5
- 5.5 Send PAR (Peak-to-Average Ratio)..... 5-7
- 5.6 Dialing..... 5-8
- 5.7 Parameter Values for Send Sweep..... 5-10

**6. CONNECTION AND CONFIGURATION..... 6-1**

- 6.1 Introduction ..... 6-1
- 6.2 General ..... 6-1
- 6.3 Connectors and Cables..... 6-2
- 6.4 600 /900 Line Termination Impedances..... 6-7
- 6.5 Impedance Adapter ..... 6-9
- 6.6 Configurations..... 6-10

**7. OPERATING INSTRUCTIONS..... 7-1**

- 7.1 Introduction ..... 7-1
- 7.2 General Instructions and Notes..... 7-3
- 7.3 General Operating Notes..... 7-3
- 7.4 Figure Format ..... 7-4
- 7.5 General Switch Setup..... 7-6
- 7.6 Multiple Use of Keys..... 7-8
- 7.7 Memory..... 7-9
- 7.8 General Procedure to Set New Parameter Values..... 7-12
- 7.9 Send (Generator) Modes and Parameter Settings..... 7-13
- 7.10 Types of Send Signals..... 7-13
- 7.11 Send Quiet..... 7-14
- 7.12 Set Parameters from Quiet Display ..... 7-15
- 7.13 Send Momentary Variable Tones..... 7-17
- 7.14 Send 1004 Hz..... 7-18
- 7.15 Send Continuous Variable Tone..... 7-19

AM-48 Test Set	(18-0015)	Table of Contents
7.16	Send Set of Slope Tones .....	7-19
7.17	Send Variable Sweep .....	7-20
7.18	Send PAR Waveform .....	7-22
7.19	Send Momentary 2713 Hz Tone .....	7-22
7.20	General Instructions and Notes for MEASURE Modes .....	7-22
7.21	Accuracy of Measurements .....	7-22
7.22	Absolute and Relative Measurements .....	7-23
7.23	Special Measurement Requirements .....	7-24
7.24	Timed Tests .....	7-26
7.25	MEASURE Modes .....	7-27
7.26	Measure Level and Frequency .....	7-27
7.27	Measure Noise .....	7-28
7.28	Measure PAR .....	7-29
7.29	Measure Impulse Noise .....	7-29
7.30	Measure Notched Noise .....	7-32
7.31	Measure S/N Ratio .....	7-34
7.32	Measure Phase Jitter .....	7-34
7.33	Measure Amplitude Jitter .....	7-35
7.34	Measure Transients .....	7-36
7.35	Miscellaneous Operations .....	7-40
7.36	Store and Recall .....	7-40
7.37	Dialing .....	7-43
7.38	Talking .....	7-45
7.39	Printing .....	7-45
7.40	Auto Study Result Save .....	7-56
7.41	Impedance Adapter Measurement Corrections .....	7-56
7.42	Auto Calibrate .....	7-59
<b>8.</b>	<b>EXPLANATION AND APPLICATION OF MEASUREMENTS .....</b>	<b>8-1</b>
8.1	Introduction .....	8-1
8.2	Units of Measurement .....	8-1
8.3	Level (Loss or Gain) and Frequency .....	8-4
8.4	Idle Channel Noise .....	8-4

<b>Table of Contents</b>	<b>(18-0015)</b>	<b>AM-48 Test Set</b>
8.5 Notched Noise (Noise with Tone) .....		8-4
8.6 Signal-to-Noise (S/N) Ratio .....		8-5
8.7 P/AR Measurements.....		8-6
8.8 Gain Slope .....		8-8
8.9 Idle Channel Impulse Noise .....		8-9
8.10 Phase Jitter .....		8-11
8.11 Amplitude Jitter .....		8-11
8.12 Notched Impulse Noise .....		8-12
8.13 Phase Hits.....		8-12
8.14 Gain Hits .....		8-12
8.15 Dropouts.....		8-12
<b>9. CIRCUIT DIAGRAMS.....</b>		<b>9-1</b>
9.1 Introduction .....		9-1
9.2 AM-48 Simplified Block Diagram.....		9-1
9.3 Impedance Adapter Schematic .....		9-3
<b>10. WARRANTY, SERVICE, AND CALIBRATION .....</b>		<b>10-1</b>
10.1 Warranty.....		10-1
10.2 Service Policy .....		10-1
10.3 Calibration Policy .....		10-1
10.4 Return of Unit.....		10-2
<b>11. GLOSSARY.....</b>		<b>11-1</b>

## List of Figures

Figure 3-1. AM-48 Location of Components.....	3-3
Figure 3-2. AM-48 Connectors.....	3-4
Figure 3-3. Standard AM-48 Cables .....	3-4
Figure 3-4. Optional AM-48 Cables.....	3-5
Figure 3-5. AM-48 Switch Identification Numbers .....	3-6
Figure 3-6. AM-48 Keyboard Identification Numbers .....	3-15
Figure 3-7. AM-48 Liquid Crystal Display .....	3-18
Figure 3-8. Hand-Held Printer, External View.....	3-22
Figure 3-9. Hand-Held Printer, Internal View.....	3-23
Figure 3-10. Impedance Adapter.....	3-24
Figure 4-1. Battery Installation and Selector Switch.....	4-2
Figure 5-1. AM-48 Setup for Self-Test (Looped Back) .....	5-2
Figure 5-2. General Switch Setup for Self Test .....	5-3
Figure 5-3. Quiet Send Mode Self Test.....	5-4
Figure 5-4. Send 1004 Hz Self Test, Switch Settings.....	5-6
Figure 5-5. Send 1004 Hz Self Test, Displays.....	5-7
Figure 5-6. Send PAR (Peak-to-Average Ratio).....	5-8
Figure 5-7. Dialing.....	5-10
Figure 5-8. Default Parameter Settings for SWEEP Send Mode.....	5-14
Figure 6-1. 2-Wire AM-48 Line Connections.....	6-3
Figure 6-2. 4-Wire AM-48 Line Connections.....	6-4
Figure 6-3. AM-47 Hand-Held Printer Connection with AC Power.....	6-5
Figure 6-4. 4-Wire End-to-End Testing .....	6-11
Figure 6-5. 4-Wire Testing with Responder .....	6-13
Figure 6-6. 2-Wire Network Testing with Responders.....	6-14
Figure 7-1. Parameter Settings from <u>QUIET SEND</u> Display .....	7-15
Figure 7-2. Parameter Settings from <u>1004 Hz</u> and <u>VAR</u> Tone Displays ...	7-18



**Table of Contents (18-0015) AM-48 Test Set**

Figure 7-3. Parameter Settings from 3-TONE Slope and PAR SEND Displays..... 7-20

Figure 7-4. Parameter Settings from SWEEP SEND Display..... 7-21

Figure 7-5. L/E, NOISE, and PAR MEASURE Displays..... 7-28

Figure 7-6. IMPLS MEASURE Displays..... 7-32

Figure 7-7. Notched NOISE and S/N Ratio MEASURE Displays ..... 7-33

Figure 7-8. Phase JTR and Amplitude JTR MEASURE Displays..... 7-35

Figure 7-9. TRANS MEASURE Displays ..... 7-39, 7-40

Figure 7-10. Recall and Store Operations ..... 7-42

Figure 7-11. SEND Printouts..... 7-52

Figure 7-12. MEASURE Printouts, Absolute Measure Mode..... 7-54

Figure 7-13. MEASURE Printouts, Relative Measure Mode..... 7-55

Figure 7-14. Impedance Adapter Correction Value Memory Aid..... 7-58

Figure 7-15. AM-48 Auto Calibrate Prompts..... 7-60

Figure 8-1. Level and Noise Units of Measurement ..... 8-2

Figure 8-2. Impulse Noise Thresholds and Blanking Intervals..... 8-10

Figure 9-1. Simplified Block Diagram of the AM-48..... 9-2

Figure 9-2. Schematic Diagram of the Impedance Adapter ..... 9-4

## List of Tables

Table 1-1. AM-48 General Technical Specifications .....	1-5
Table 1-2. AM-48 Generator (Send) Technical Specifications.....	1-6
Table 1-3. AM-48 Receiver (Measure) Technical Specifications.....	1-8
Table 1-4. AM-48 Power/Physical Technical Specifications .....	1-11
Table 2-1. AM-48 Standard Equipment .....	2-2
Table 2-2. AM-48 Optional Equipment .....	2-2
Table 3-1. Front Panel/Switches Color Coding.....	3-2
Table 3-2. AM-48 SEND, MEASURE, and FILTER Menus.....	3-19
Table 3-3. AM-47 Hand-Held Printer Technical Specifications.....	3-21
Table 7-1. Setup Requirements for Different Keyboard Applications .....	7-8
Table 7-2. Steps for Up and Down Arrow Keys.....	7-9
Table 7-3. User-Programmable Parameter Values Stored in Memory.....	7-11
Table 7-4. Acceptable Holding Tone Ranges.....	7-25
Table 7-5. Special Measurement Requirements.....	7-26
Table 7-6. Setup Requirements for Dialing.....	7-44
Table 7-7. MF and DTMF Tone Pairs.....	7-44
Table 7-8. Impedance Adapter Correction Values.....	7-57
Table 8-1. P/AR Requirements of Telephone Lines.....	8-6

## ADDENDUM

### OPTION 25-0087-A CHANGES

This addendum describes the changes to the operation of a unit that has been equipped with the 25-0087-A option. Also included in this addendum is a general notice concerning a change to the 48-0062 test cable.

#### 1. 50 Hz Send and Measure Accuracy

The AM-48 circuits were originally designed for a lower frequency limit of 200 Hz. At 50 Hz measurement, the send and measure losses are higher. The tables on pages 1-6 and 1-8 are changed as follows:

Page 1-6:

	GENERATOR ACCURACY			
	50 Hz	200 Hz	15 KHz	20 KHz
+10 dBm	±0.5	±0.2		±0.5
-40 dBm				
-50 dBm	±0.8	±0.5		±1.0

Page 1-8:

	RECEIVER ACCURACY			
	50 Hz	200 Hz	15 KHz	20 KHz
+10 dBm	±0.5	±0.2		±0.5
-40 dBm				
-65 dBm	±0.8	±0.4		±0.8

## 2. 13 dBm Send Capability

The unit must be set at 600  $\Omega$  impedance in order to transmit a level higher than 10 dBm. The accuracy of the sending level after being extended from 10 to 13 dBm is  $\pm 0.01$  dB. The measure display is not changed; as is the case with units without this option, the display will read "OVER" for received levels over 10 dBm.

## 3. 0dBm Noise Measurements

The unit must be set at 600  $\Omega$  impedance and C-MSG filter. It also must use battery supply; the AC Adapter can introduce about 6dBm even at quiet mode.

**IMPORTANT NOTICE:** The tip and ring colors for the optional 48-0062 cables manufactured after 5/7/92 are GREEN = tip (or A), and RED = ring (or B). This is opposite to what is shown in Figure 3-4, which applies to cables manufactured before 5/7/92. There is a label at the minigator end of the later cables that calls out the color codes. ("T/GRN, R/RED, S/BLK").

# 1. INTRODUCTION

## 1.1 Manual Overview

This instruction manual describes the Ameritec Corporation AM-48 and AM-48E Personal Transmission Test Sets.

**Note:** Throughout this manual, all references to the "AM-48" also apply to the "AM-48E", unless otherwise noted. See ¶1.4 for a summary of the differences between the AM-48 and the AM-48E.

The other paragraphs in this Introduction section are:

- 1.2 General Description
- 1.3 AM-48 Technical Specifications
- 1.4 AM-48E Technical Specifications

The balance of the manual is divided into the following sections:

- 2. Receiving and Unpacking
- 3. Physical and Functional Description
- 4. Power Considerations
- 5. Self-Test Instructions
- 6. Connection and Configuration
- 7. Operating Instructions
- 8. Explanation and Application of Measurements
- 9. Circuit Diagrams
- 10. Warranty, Service, and Calibration
- 11. Glossary
- Index

**Note:** It is suggested that the foldout at the back of the manual be extended when using this manual. The FOLDOUT, a front view of the AM-48, defines the numbers of the switches which are used to identify the switches throughout this manual.

Glossary. Refer to the Glossary to become familiar with the terminology used in this manual.

Power. Be sure to read Section 4 and observe the WARNING in ¶4.3 before powering up the AM-48.

Self Test. Perform the Self Test in Section 5 to:

1. confirm that all AM-48 circuits and basic functions are working properly, and
2. obtain "hands-on" experience with the AM-48 to learn how the controls operate.

Transmission Measurements. Note that Section 7, Operating Instructions, gives procedures to perform transmission measurements. For explanation and application of the measurements, see Section 8.

## 1.2 General Description

Definition and Purpose. In one (1) hand-held unit, the AM-48 provides the field engineer with two (2) instruments:

1. a transmission test set, and
2. a telephone "butt-set".

The transmission test set tests the integrity and quality of 2-wire or 4-wire voice and data transmission lines by sending selected analog signals and measuring standard parameters of the received signals.

The telephone "butt set" enables the field engineer to dial up and speak back-and-forth with a field engineer at the far end of the system. The compact and light-weight AM-48 eliminates the need to carry multiple, bulky test sets.

#### Functional Overview

AM-48 can send:

- any frequency from 200 Hz to 20 kHz @ -50 to +10 dBm
- continuous 3-tone slope (404, 1004, 2804 Hz)
- continuous, user-defined, sweep tones
- fixed 1004 Hz
- P/AR waveform
- momentary 2713 Hz for WECO 829 loopback

AM-48 can measure:

- level, -65 to +10.9 dBm (absolute or relative)
- frequency, 0 to 19,999 Hz
- idle channel noise
- noise with tone
- three-level impulse noise
- phase jitter
- gain jitter
- transients (dropouts, phase and gain hits, impulse noise)
- signal-to-noise (S/N) ratio
- peak-to-average ratio (P/AR)

Noise filters provided (each with optional 1010 Hz notch)::

- C-Message (Psophometric for AM-48E)
- 3 kHz
- 15 kHz
- Program (Sound-weighted for AM-48E)

## Other features:

- High impedance bridge, 600 or 900 Ohm termination
- Display prompts help in set-up and testing sequences
- On-board memory can store & recall up to 10 user-defined test set-ups
- Dials: pulse, DTMF, and MF
- Talk/Listen capability
- Printer interface for hard copy of set-up and test results
- Battery life: Alkaline, 6 to 7 hours; NiCad, 3 to 4 hours
- NiCad batteries can be recharged without removing them from the unit

Testing Configurations: (For details, see ¶6.6)

There are three (3) basic AM-48 configurations used to test 2-wire/4-wire telephone/data communication lines:

1. End-to-end -- requiring two (2) AM-48 units
2. Loopback
3. Testing with responders

### 1.3 AM-48 Technical Specifications

AM-48 technical specifications are presented in four (4) parts:

1. General (Table 1-1)
2. Generator (Send) (Table 1-2)
3. Receiver (Measure) (Table 1-3)
4. Power/Physical (Table 1-4)



Table 1-1. AM-48 General Technical Specifications

Characteristic	Specification
<b>Measurements</b>	
Level	-65 to +10.9 dBm
Frequency	0 to 19,999 Hz
Noise	10 to 99 dBm
Notched Noise	10 to 99 dBm
Signal to Noise	0 to 60 dB
P/AR	0 to 120
Amplitude Jitter	0.0 to 25.0%
Phase Jitter	0.0 to 25.0 degrees
3-Level Impulse Noise	Counts from 0 to 9999
<b>Transient Measurements</b>	
Dropouts	0 to 9999
Gain Hits	0 to 9999
Phase Hits	0 to 9999
3-Level Impulse Noise	Counts from 0 to 9999
<b>Dial</b>	Built-in 16 button keypad for dial pulse, DTMF (Touch Tone), or MF dialing.
<b>Talk</b>	Built-in microphone and speaker with push-to-talk operation on both 2-wire and 4-wire lines. Earphone jack for optional earphone.
<b>Holding</b>	A single line holding circuit is provided for 2-wire operation, or the send pair of 4-wire circuits. It electronically simulates a holding coil with a DC resistance of approximately 200 ohms. The AC impedance is high enough to give no more than 0.2 dB loss at 600 ohm impedance.
<b>Impedances</b>	600 and 900 ohm.
	Balance > 60 dB below 4 kHz, decreasing 6 dB/octave above 5 kHz.
	Return loss > 30 dB 200-5000 Hz, > 15 dB 5-20 kHz.
	DC blocking - 150 Volts.
	Bridging impedance > 25 kohms.

Characteristic	Specification
Printer	Current loop interface to optional printer for hard copy of unit setup and measurement results
Store/Recall	<p>10 complete unit setups may be stored by user in internal nonvolatile memory, and recalled for ease of repeating frequently-used tests. In addition, the results of the last impulse or transient study (along with the associated setups) are stored to nonvolatile memory at the completion of the study. They are recalled automatically whenever the unit is turned on.</p> <p>Also stored in nonvolatile memory are four (4) user-set parameters (each set from the QUIET mode):</p> <ol style="list-style-type: none"> <li>1. Touch Tone/MF Dial Level</li> <li>2. Power Down Time with momentary power switch</li> <li>3. Blanking interval for impulse and transient tests</li> <li>4. 10 user-programmable momentary frequencies</li> </ol>

Table 1-2. AM-48 Generator (Send) Technical Specifications

Characteristic	Specification																
Variable	<p><u>Frequency:</u> 200 Hz to 19,999 Hz in 1 Hz steps. Frequency may be entered directly via the keypad or stepped up or down in 10 Hz steps with auto-repeat steps of 100 Hz (4 steps/second) for fast frequency slewing. Frequencies are crystal-controlled and accurate to <math>\pm 72 \text{ Hz} \pm 0.1\%</math>.</p> <p><u>Level:</u> -50.0 dBm to +10.0 dBm in .1 dB steps. Level may be entered directly via the keypad or stepped up or down in .1 dB steps with auto-repeat steps of 1.0 dB (4 steps/second) for fast level slewing. Level accuracy is as follows:</p> <table border="1" style="margin-left: auto; margin-right: auto;"> <thead> <tr> <th></th> <th>200 Hz</th> <th>15 kHz</th> <th>20 kHz</th> </tr> </thead> <tbody> <tr> <td>+10 dBm</td> <td><math>\pm 0.2</math></td> <td><math>\pm 0.5</math></td> <td></td> </tr> <tr> <td>-40 dBm</td> <td></td> <td></td> <td></td> </tr> <tr> <td>-50 dBm</td> <td><math>\pm 0.5</math></td> <td><math>\pm 1.0</math></td> <td></td> </tr> </tbody> </table>		200 Hz	15 kHz	20 kHz	+10 dBm	$\pm 0.2$	$\pm 0.5$		-40 dBm				-50 dBm	$\pm 0.5$	$\pm 1.0$	
	200 Hz	15 kHz	20 kHz														
+10 dBm	$\pm 0.2$	$\pm 0.5$															
-40 dBm																	
-50 dBm	$\pm 0.5$	$\pm 1.0$															
1004 Hz	A fixed 1004 Hz holding tone is provided. The frequency is accurate to $\pm 0.25\%$ . Level is the same as variable.																

Characteristic	Specification
3-Tone	A three-tone slope frequency mode is provided, which cycles continuously between 404 Hz, 1004 Hz, and 2804 Hz, giving 5 seconds of each tone. Frequency accuracy is the same as variable. Level is the same as variable.
Sweep	A programmable frequency sweep generator is provided. It generates tones continuously from a user-specified START frequency (200 Hz to 19,999 Hz) to a user-specified STOP frequency (200 Hz to 19,999 Hz), at a user-specified frequency STEP interval (1 Hz to 19,999 Hz), and at a user-specified step RATE (0.1 second to 19,999 seconds/frequency). Frequency accuracy is the same as variable. Level is the same as variable.
PAR	A PAR waveform generator is provided, which generates the 16 simultaneous frequency PAR waveform per Bell 41009 specifications. The level may be set from -40.0 dBm to 0.0 dBm, with 0.1 dBm resolution. Level accuracy is $\pm 0.5$ dBm.
Quiet	In quiet mode, the line is terminated with a passive resistance equal to the line impedance. Also, when in Quiet, one of 10 user-programmable tones may be momentarily applied to the line by depressing the (0) thru (9) keys.  Programmable from this mode are (1) Touch Tone dial level (-50.0 to 7 dBm), (2) Power down Time Off (1 to 255 minutes), (3) Impulse and Transient test Blanking Interval (1 to 255 ms), and (4) 10 user-programmable tones for later instant recall.
Aux Tone	A momentary pushbutton is provided for the generation of an auxiliary tone (2713 Hz), used to activate remote 829-type loopback devices.
SF Skip	A Signaling Frequency (SF) Skip mode prevents the generation of tones between 2450 Hz and 2750 Hz in variable or sweep modes.
Distortion	Total distortion is < -50 dB @ 1004 fixed tone and < -40 dB @ any other frequency.

Table 1-3. AM-48 Receiver (Measure) Technical Specifications

Characteristic	Specification																
Level/Freq	<p><u>Level</u> is measured with an average responding detector. Range is -65.0 to +10.9 dBm with 0.1 dBm resolution. Accuracy is as follows:</p> <table border="1"> <thead> <tr> <th></th> <th>200 Hz</th> <th>15 kHz</th> <th>20 kHz</th> </tr> </thead> <tbody> <tr> <td>+10 dBm</td> <td>±0.2</td> <td>±0.5</td> <td></td> </tr> <tr> <td>-40 dBm</td> <td></td> <td></td> <td></td> </tr> <tr> <td>-65 dBm</td> <td>±0.4</td> <td>±0.8</td> <td></td> </tr> </tbody> </table> <p><b>Note:</b> Accuracy is ±0.1 dBm at 1004 Hz from -20 dBm to 0.0 dBm.</p> <p><u>Frequency</u> is measured from 200 Hz to 19,999 Hz with an accuracy of ±0.01% ±1 Hz, and a resolution of 1 Hz. Input level -40 to +10 dBm.</p>		200 Hz	15 kHz	20 kHz	+10 dBm	±0.2	±0.5		-40 dBm				-65 dBm	±0.4	±0.8	
	200 Hz	15 kHz	20 kHz														
+10 dBm	±0.2	±0.5															
-40 dBm																	
-65 dBm	±0.4	±0.8															
PAR	<p>Peak-to-Average Ratio (PAR) is measured from 0 to 120 PAR units to a resolution of 1 PAR unit. Accuracy is ±2 from 30 to 110, ±4 from 0 to 120 over a signal range of -40 to 0 dBm.</p> <p>PAR signal level is measured from -40 to 0 dBm, with a resolution of 1 dBm, using an RMS detector.</p>																
Noise	<p>Noise is measured with an RMS responding detector from 10 to 99 dBm to 1 dBm resolution. Accuracy is ±1 dBm from 20 to 99 dBm, and ±2 dBm from 10 to 20 dBm.</p> <p>Weighting Filters are 3 kHz flat, 15 kHz flat, CMSG, and Program filter.</p>																
Notched Noise	<p>Notched Noise is the same as noise with the addition of a 1010 Hz notch filter, minimum 50 dB deep from 995 to 1025 Hz.</p>																
S/N ratio	<p>Signal-to-Noise (S/N) ratio display the ratio of signal (holding tone) to notched noise. The signal must be -40 to +10 dBm. The notched noise may be 10 to 70 dBm. The S/N ratio may be from 10 to 50 dB. Resolution is 1 dB. Accuracy is ±1 dB for notched noise 20 to 70 dBm, and ±2 dB for notched noise from 10 to 20 dBm.</p>																

Characteristic	Specification
Amplitude Jitter	<p>Displays the incidental amplitude modulation of a holding tone. The holding tone must be -40 to +10 dBm, 990 to 1030 Hz. Amplitude jitter is displayed from 0.0 to 25.0% with a resolution of .1% and an accuracy of <math>\pm 2\%</math>, <math>\pm 5\%</math> of reading.</p> <p>Weighting filter selection: 20-300 Hz or 4-300 Hz.</p>
Phase Jitter	<p>Displays the incidental phase modulation of a holding tone. The holding tone must be -40 to +10 dBm, 990 to 1030 Hz. Phase jitter is displayed in degrees from 0.0 to 25.0 degrees with a resolution of .1 degree and an accuracy of <math>\pm 2</math> degree, <math>\pm 5\%</math> of reading.</p> <p>Weighting filter selection: 20-300 Hz or 4-300 Hz.</p>
Impulse Noise	<p>Three (3) noise thresholds are established: <u>Low</u>, <u>Middle</u>, and <u>High</u> levels, with an equal interval between them called the <u>Delta</u>. The maximum High threshold is 105 dBm for 600 ohm impedance (or 104 dBm for 900 ohm). The minimum Low threshold is 30 dBm. Delta can be 2, 3, 4, or 6 dB. Threshold accuracy: <math>\pm 1</math> dB. A user-selected blanking interval of 1 to 255 ms for each threshold, blocks further counting of impulses at that threshold.</p> <p>The study duration timer may be set from .1 minute to 1999.9 minutes in .1 minute steps, or continuous. Each threshold has a count capacity of 0-9999. Weighting filters same as noise.</p>
Transients	<p>Counts dropouts, gain hits, phase hits, and 3-level impulse noise with tone. Holding tone must be -40 to +10 dBm, 995 to 1025 Hz</p> <p><u>Dropout threshold</u> is -12 dB from the initial level of the holding tone. A dropout will be counted if the holding tone drops below the threshold for at least 4 ms <math>\pm</math> .5 ms. Counting of dropouts, gain hits, phase hits, and impulses is inhibited for a blanking interval which lasts until 1 second after the holding tone is restored to a level above the dropout threshold.</p>

Characteristic	Specification
Transients (cont.)	<p><u>Gain hit threshold</u> can be 2, 3, 4, or 6 dB. A gain hit will be counted if the level of the holding tone changes up or down by more than the threshold for at least 4 ms <math>\pm</math> .5 ms. A blanking interval, that is user-set from 1 to 255 ms, blocks further counting of gain hits.</p> <p><u>Phase hit threshold</u> can be 5 to 45 degrees in 1 degree steps, with an accuracy of <math>\pm</math> .5 degrees <math>\pm</math> 10% of the setting. A phase hit will be counted if the phase of the holding tone changes by more than the threshold for at least 4 ms <math>\pm</math> .5 ms. A blanking interval, that is user-set from 1 to 255 ms, blocks further counting of phase hits.</p> <p>The three-level impulse noise <u>low threshold</u> can be set from 30 to 110 dB<sub>rn</sub> with threshold differences of 2, 3, 4, or 6 dB. Threshold accuracy: <math>\pm</math> 1 dB. An independent blanking interval for each threshold, user-set from 1 to 255 ms, blocks further counting of impulses at that threshold.</p> <p>The study duration timer may be set from .1 minute to 1999.9 minutes in .1 minute steps, or set to 0 for a continuous study.</p> <p>Each transient has a count capacity of 0-9999.</p> <p>Filters same as noise.</p>
Damping	<p>A damp mode reduces the display update rate from approximately 4 times/second to approximately 2 times/second for reading widely fluctuating measurements.</p> <p>The same switch, when in &lt;DAMP&gt; position, also changes the monitoring point of the receive (RCV) monitor speaker to the output of the auto-range amplifier (significantly increasing the speaker level).</p>
Term/Bridge	<p>When in terminate, the receiver terminates the line in the selected impedance. When in bridge, the line is bridged by a high impedance, causing no more than .2 dB loss on a 600 ohm line.</p>

Table 1-4. AM-48 Power/Physical Technical Specifications

Characteristic	Specification
Power	<p>Four 1.5 VDC "AA" alkaline batteries provide about six hours operation. NiCad batteries provide about half the life of alkaline.</p> <p>External AC adapter powers unit from 120 VAC and charges optional NiCad batteries in the unit.</p> <p><u>Auto shutoff</u> after last switch actuation is user-programmable for 0 (no shutoff), or from 1 to 255 minutes. May be overridden by placing power switch in the &lt;ON&gt; position. Does not turn itself off while timed study is in progress.</p>
Physical	<p><u>Size</u>: 4.2" (106mm)W x 7.6" (193mm)H x 1.7" (43mm) D.</p> <p><u>Weight</u>: 23 oz. with alkaline batteries (slightly less with NiCad).</p> <p><u>Connections</u> to phone line via dual bantam jacks and RJ11C modular jack.</p>

## 1.4 AM-48E Technical Specifications

AM-48E is an international version transmission test set which meets CCITT standards. All specifications for the AM-48 in Tables 1-1 thru 1-4 are identical for the AM-48E, except as described below:

1. Instead of the C-Message (CMSG) noise-weighting filter, the AM-48E has the Psophometric (PSHO) noise-weighting filter. See Figures 3-6 and 3-7.
2. Instead of the Program (PROG) noise-weighting filter, the AM-48E has the Sound-weighted (SWTD) filter. See Figures 3-6 and 3-7.
3. Instead of the 3TONE slope frequency send mode of 404 Hz, 1004 Hz, and 2804 Hz @ 5 seconds, the AM-48E has a 4-tone SLOPE frequency send mode of 404 Hz, 1004 Hz, 2004 Hz, and 3004 Hz @ 5 seconds. See Figures 3-6 and 3-7.

4. Instead of Signal Frequency (SF) Skip 2450 Hz to 2750 Hz, the AM-48E has SF SKIP from 2130 Hz to 2430 Hz.
5. On all noise displays, instead of units of dBm, the AM-48E displays the noise in units of dBm. See ¶8.2 and Figure 8-1 for definitions and corresponding values of dBm and dBm units.



## 2. RECEIVING AND UNPACKING

### 2.1 Introduction

This section covers procedures to follow when the AM-48 is first received in its shipping container:

- 2.2 Inspection when Received
- 2.3 Verification of Contents

### 2.2 Inspection when Received

The AM-48 was thoroughly tested and carefully packed before shipment, and was in good condition when turned over to the carrier for transport.

The name of the carrier will be noted on the packing slip which accompanied the shipment.

Upon receipt, thoroughly inspect the outside of the shipping container for damage. If the container is damaged, and the AM-48 is found to be damaged or non-operational, immediately contact the carrier and submit a claim for damages.

**Note:** To test if the unit is operational, see Section 4 for Power Considerations and Section 5 for Self-Test Instructions.

### 2.3 Verification of Contents

After opening and unpacking, use the following equipment lists to verify that all ordered items have been received. Note that some items are standard and always included; other items are optional, and only shipped when specially ordered.

Table 2-1. AM-48 Standard Equipment

Amount	Part Number	Description
1		AM-48 unit
4	24-0006	AA-size 1.5 VDC alkaline batteries
1	48-0049	Modular input cord with minigator clips
1	82-0005	Earphone
1	70-0029	AC Adapter
1	18-0015	AM-48/AM-48E Instruction Manual
1	87-0009	Plastic transport case, made to hold AM-48, AC Adapter, Cables, and AM-47 Hand-held printer.

Table 2-2. AM-48 Optional Equipment

Amount	Part Number	Description
1	24-0005	Impedance Adapter (1200, 150, 135, 75 ohms)
4	24-0006	AA-size alkaline batteries (replacement set)
4	24-0007	AA-size NiCad (rechargeable) batteries
1	AM-47	Hand-held printer - includes roll of paper, ribbon cartridge, and 48-0079 Printer Cable.
1	26-0014	roll of paper for Hand-held printer
1	26-0015	ribbon cartridge for Hand-held printer
1	48-0047	Bantam (M) to Bantam (M) Cable (6') (two required for 4-wire operation)
1	48-0048	Bantam (M) to 310 (M) Cable (6') (two required for 4-wire operation)
1	48-0049	Modular to Minigator Cable (7')
1	48-0062	Bantam (M) to Minigator Cable (6') (two required for 4-wire operation)
1	48-0078	Printer Cable for use with an EIA printer
1	48-0079	Printer Cable for use with Ameritec Hand-held printer.

See Figure 3-3 for illustrations of the cables listed in Tables 2-1 and 2-2.

### 3. PHYSICAL & FUNCTIONAL DESCRIPTION

#### 3.1 Introduction

This section illustrates and explains the components of the AM-48.

Also described are the Hand-held Printer and the Impedance Adapter.

This section is divided into the following paragraphs:

- 3.2 General
- 3.3 Component Location
- 3.4 Connectors and Cables
- 3.5 Switches
- 3.6 Keyboard
- 3.7 Display
- 3.8 Microphone/Speaker
- 3.9 Hand-held Printer
- 3.10 Impedance Adapter

See ¶4.2 for the description of the battery compartment.

#### 3.2 General

The AM-48 weighs 23 ounces (with batteries) and measures 4.2" x 7.6" x 1.7" (106mm x 193mm x 43mm).

All electronic components are mounted on three (3) interlocking printed circuit boards, housed in a high-impact injection-molded ABS plastic case. The case is factory-sealed, since there are no user-serviceable parts inside.

To stand or hang the AM-48, use the hinged wire bail at the top of the case. Lift the bail until it snaps into the detent of the desired position. The front panel and switches are color-coded to tie together associated functions.

Table 3-1. Front Panel/Switches Color Coding

Color	Description
<b>Black &amp; Blue</b>	Line controls. Associated with configuring the AM-48 for the type of line to be measured.
<b>Yellow</b>	Send controls. Associated with selecting the desired signal generator (send) function and controlling the signal generator.
<b>Red/Pink</b>	Measure controls. Associated with selecting the desired measurement function and measurement characteristics.
<b>Orange</b>	On menus: all noise-weighting filters and the measurements that require a noise-weighting filter.

### 3.3 Component Location

Figure 3-1 shows the location of components on the front panel and sides.

Front Panel. Liquid crystal display and keyboard.

Sides. There are two (2) slide switches on the left side and a total of 12 color-coded rocker switches along the left and right sides. The rocker switches are protected from abuse by integral "ribs" molded into the case. A thumb wheel speaker volume control and slots for the microphone are also located on the left side.

Top and Bottom. The slots at the top are for the speaker.

Connectors for the transmission line, AC adapter, earphone, and printer are located along the bottom, as illustrated in Figure 3-2.

Rear Panel. You may access the battery compartment through a slide door in the rear panel. See ¶4.2 and 4.3 for details.

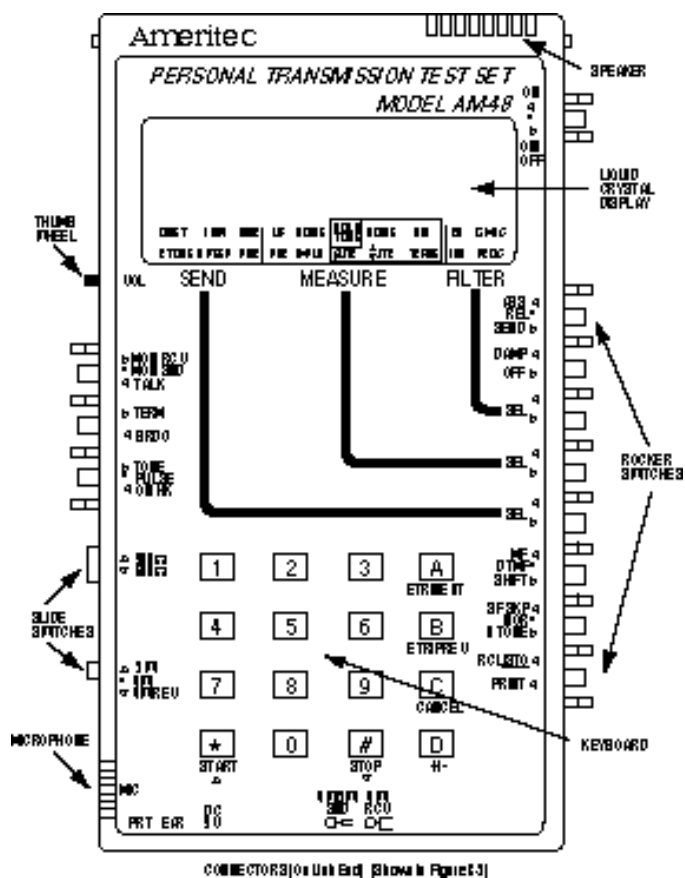

Figure 3-1. AM-48 Location of Components

### 3.4 Connectors and Cables

AM-48 connectors are shown in Figure 3-2. Figures 3-3 and 3-4 illustrate the standard and optional cables available for use with the AM-48. See ¶6.3 for cable connection instructions.

Note: The AM-47 Hand-held Printer includes its own cable, P/N 48-0079. The Printer Cable P/N 48-0078 is for connection to the RS-232 port (25-pin female) of most other serial EIA printers..

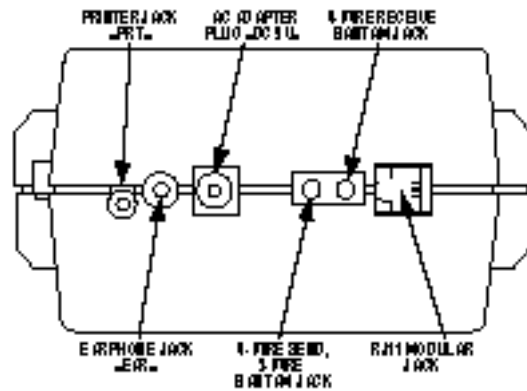

Figure 3-2. AM-48 Connectors

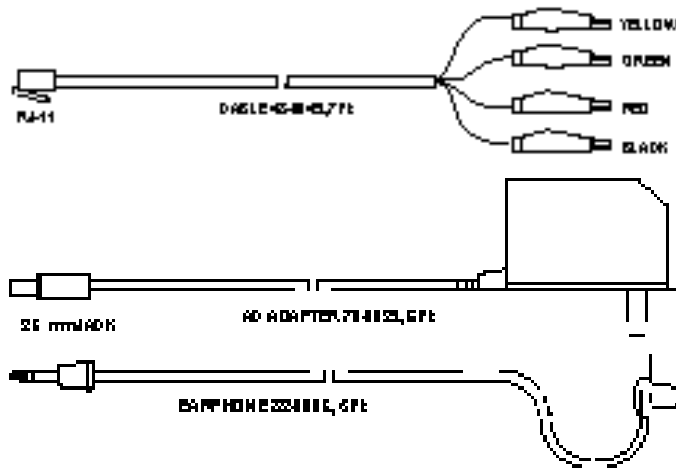

Figure 3-3. Standard AM-48 Cables

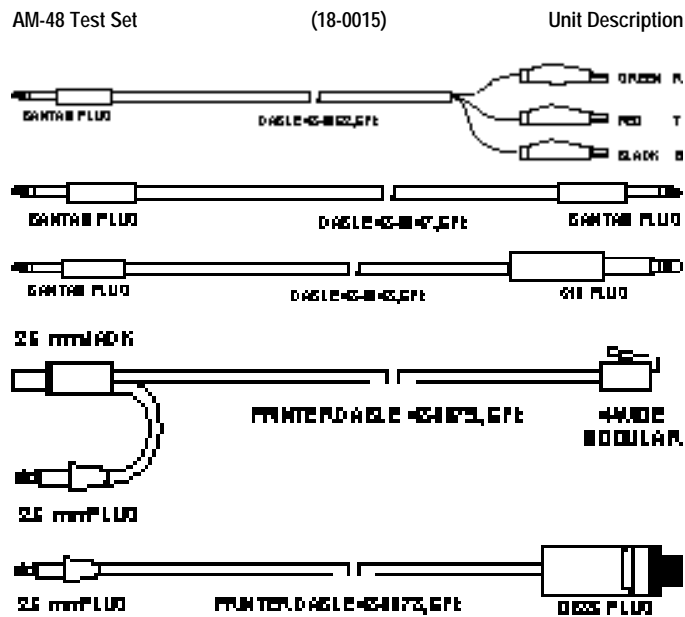

Figure 3-4. Optional AM-48 Cables

### 3.5 Switches

Figure 3-5 shows the location of the AM-48 switches. The functional descriptions of the switches in this paragraph follows the same numbering scheme as Figure 3-5.

**Note:** Throughout this manual, a switch position indicated on the front panel is referred to with angular brackets, <>. For example, <ABS> refers to the absolute measurement position of Switch 2.

Switches are referred to by number throughout this manual. See Figure 3-5 for ease of reference of switch numbers.

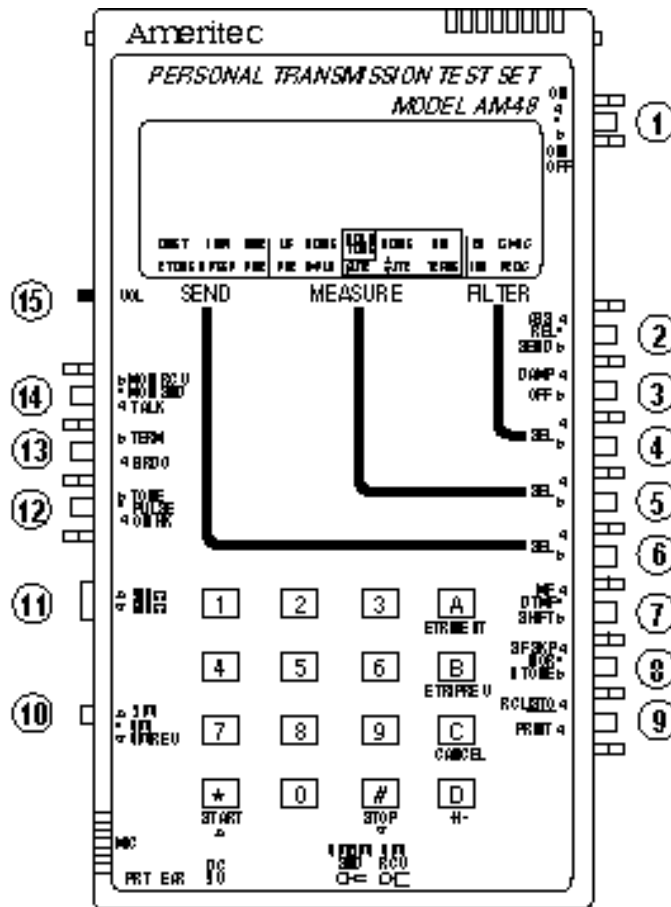

Figure 3-5. AM-48 Switch Identification Numbers



There are three (3) types of switches:

Thumb Wheel: "Switch" 15 is the only thumb wheel. It is a volume control. Push up (toward the front panel) on <VOL> to increase the volume of the monitor speaker. Push down on <VOL> to decrease the monitor speaker volume.

Slide Switches: Switches 10 and 11 are slide switches. Push these switches toward the top or the bottom in the direction indicated by the arrows on the front panel to select the desired line parameter.

Rocker Switches: The other 12 switches are rocker switches. The action of these switches is rather like a rocking chair. Rock the appropriate switch toward or away from the front panel as indicated by the arrows to activate the desired function. There are various combinations between toggle and/or momentary switching action as explained in the functional descriptions which follow (reference Figure 3-5).



Power. Combination toggle and momentary rocker switch.

- Set to <ON> position for power to be on continuously.
- To allow the AM-48 to power down by itself, turn the power on by momentarily pressing the switch toward the <ON/OFF> position. The power will shut off automatically after the TIME OFF setting, if the unit is left unattended. (See ¶7.12 for instructions to set the time).
- To turn the power off, momentarily press the switch toward the <ON/OFF> position.

**2**

Display Select. Three-position toggle switch. This determines what is being viewed on the display.

- Set <ABS> to view MEASUREMENT mode in absolute reference.
- Set <REL> to view MEASUREMENT mode in relative reference.
- Set <SEND> to view the SEND mode.

See ¶7.22 and 8.2 for explanation of absolute and relative measurements.

**3**

Two-position toggle switch. This switch has a dual function:

- A. Controls the display damping. <DAMP> gives a display update of two times per second (used with widely fluctuating signals to update the display more often for better sampling of the measurement). <OFF> gives a display update of four times per second.
- B. Controls the monitoring point of the receive monitor speaker (<MON RCV> position of Switch 14). <DAMP> gives a monitoring point at the output of the auto-range amplifier, significantly increasing the speaker level.. See Figure 9-1 for a block diagram showing how this switch interacts with Switch 14.

- ④ Filter Select. Dual momentary switch. Rock up or down to move FILTER menu cursor left or right to select desired noise-weighting filter. See Table 7-5 for a list of measurements that require a noise-weighting filter. See Figure 3-8 for the FILTER menu.
- ⑤ Measure Select. Dual momentary switch. Rock up or down to move MEASURE menu cursor left or right to select desired measure mode. See Figure 3-8 for the MEASURE menu.
- ⑥ Send Select. Dual momentary switch. Rock up or down to move SEND menu cursor left or right to select desired send (generator) mode. See Figure 3-8 for the SEND menu.
- ⑦ Three-position toggle switch. See Table 7-6 for interaction of this switch with Switch 12 for dialing.
- Set <MF> to dial multi-frequency tones from the keyboard.
  - Set <DTMF> to dial DTMF (Touch Tone) from the keyboard.
  - Set <SHIFT> to enable the auxiliary functions on the keyboard. See ¶3.6 for details.

**8**

Two-position toggle plus momentary switch.

- Set <SF SKP> to skip the signaling frequency band of 2450 Hz to 2750 Hz (2130 Hz to 2430 Hz for AM-48E), avoiding the accidental transmission of signaling frequencies.
- Set <NOR> to allow the internal signal generator to be stepped through all frequencies within its range while in the SWEEP and VAR SEND modes.
- Press <X TONE> to momentarily send a 2713 Hz tone, overriding the internal signal generator. This feature is useful for actuating loopback devices. See ¶6.6 under "Loopback Testing" for the procedure to use the Western Electric Model 829 loopback device.

**9**

Dual momentary switch.

- Press <RCL/STO> to recall and/or store up to 10 test setups. See ¶7.36 for details.
- Press <PRINT> to send unit setup and measurement results to the printer port, <PRT>. See ¶3.9 and 7.39 for details.

**10**

Three-position slide switch. See Figure 6-1 and 6-2 for 2-wire and 4-wire line connections associated with this switch.

- Set <2W> to connect the internal measurement circuitry and signal generator across the 2-wire line at the <SND> jack. The signal generator source impedance of 600 or 900 ohms terminates the line in all signal generator modes except QUIET.

In QUIET mode, the line will be terminated only if Switch 13 is set to <TERM>. See Figure 6-1.

**Note:** The <RCV> jack is not used when connecting to 2-wire circuits.

- Set <4W> to connect the internal measurement circuitry to the <RCV> pair, and the internal signal generator to the <SND> pair. See the upper half of Figure 6-2.
- Set <4W REV> to reverse the send and receive pairs. See the lower half of Figure 6-2.

**11**

Two-position slide switch.

- Set <600 > (usual position for 4-wire) to
  - A. apply 600 ohms across the receive pair when Switch 13 is set to <TERM> and,
  - B. set the send pair source impedance at 600 ohms.
- Set <900 > (usual position for 2-wire) to
  - A. apply 900 ohms across the receive pair when Switch 13 is set to <TERM> and,
  - B. set the send pair source impedance at 900 ohms.

**12**

Three-position toggle switch. See Table 7-6 for interaction of this switch with Switch 7 for dialing.

- Set <TONE> to come off-hook to dial either MF or DTMF (set Switch 7 to <MF> or <DTMF> accordingly). <TONE> causes a 200 ohm DC short across T& R of the send pair to simulate a telephone off-hook condition on 2-wire dial access lines.

Press a button on the 16-button keypad to generate the appropriate DTMF or MF tone pair, depending on the setting of Switch 7. See Table 7-7 for a list of MF and DTMF tone pairs generated by pressing the keys.

- Set <PULSE> to dial pulse. Switch 7 must be set at either <MF> or <DTMF>. <PULSE> causes a 200 ohm DC short across T & R of the send pair to simulate a telephone off-hook condition on 2-wire dial access lines. Press a button on the 16-button keypad while in this mode to cause the DC short to make and break at 10 PPS, 60% break, creating dial pulses in accordance with the button pressed.
- Set <ON HK> to open the DC across T & R of the send pair to simulate a telephone on-hook condition on 2-wire dial access lines. The 16-button keypad stays operational, and if pressed, will send out DTMF or MF tones (see Table 7-7) as selected by Switch 7.



Two-position toggle switch.

- Set <TERM> to terminate the receive (<RCV>) line with a resistive impedance as elected by Switch 11.
- Set <BRDG> unterminate the receive line and bridge it only with the impedance of the measurement circuitry (>25 kohms) across the receive pair.

**Note:** In 2-wire mode, the signal generator source impedance will terminate the line with 600 or 900 ohms, regardless of the position of <TERM> / <BRDG>. If the "QUIET" send mode is selected while in 2-wire bridge mode, the signal generator will be disconnected from the send pair, and the send pair source impedance will be >25 kohms. This will allow the <TERM> / <BRDG> switch to function.

**14**

Speaker Control. Two-position toggle and momentary switch. See Figure 9-1 for a block diagram showing how this switch interacts with Switch 3.

- Set <MON RCV> to connect the internal speaker to audibly monitor the receive pair.
- Set <MON SND> to connect the internal speaker to audibly monitor the send pair.
- Push <TALK> to mute the speaker and connect the internal microphone to allow "talking" over the send pair. This feature is useful in voice communication with an assistant technician at the distant end of the transmission line being tested. It also allows the AM-48 to be used as a conventional push-to-talk telephone set on 2-wire dial networks. See ¶7.38 for more details.

**15**

Volume Control. This controls the gain of the internal speaker amplifier. Use this to set the speaker or earphone loudness to a comfortable level.

**Note:** Switch 3 and Switch 14 control the speaker/earphone monitoring point. See Figure 9-1 for a block diagram showing the interaction of these switches. When Switch 3 is set to <DAMP>, the monitor point is after the auto-range amplifier, which significantly increases the speaker level.

**WARNING**

For a given volume setting, the earphone audio level sounds much higher than the speaker level. Be careful to adjust the audio volume down before inserting the earphone into the ear.

### 3.6 Keyboard

See Figure 3-6 for the AM-48 keyboard with identification numbers which are referenced in the descriptions of this paragraph.

Auxiliary Functions. The AM-48 is equipped with auxiliary keypad functions which are identified in Figure 3-6 with reference numbers 2 thru 9. The keys and their auxiliary functions are:

- [\*] START
- [#] STOP
- [A] ETR/NEXT
- [B] ETR/PREV
- [C] CANCEL
- [D] ±

**Note:** To enable the auxiliary functions, set Switch 7 to <SHIFT>.



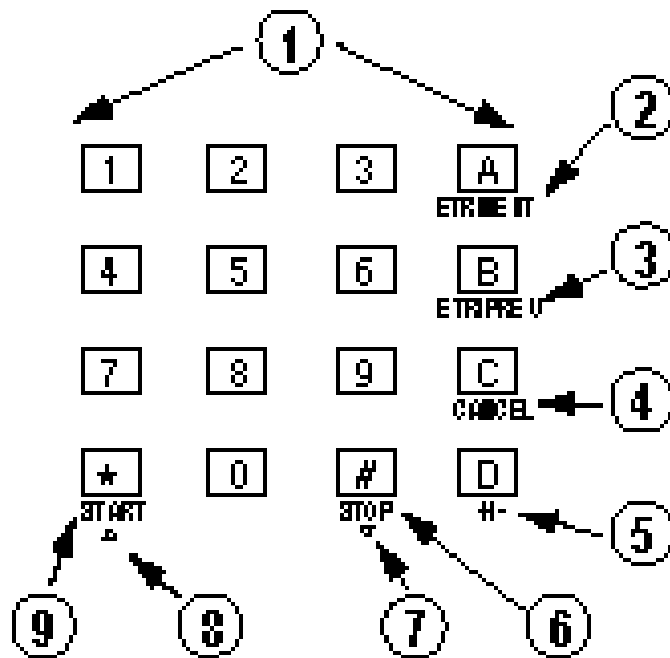

Figure 3-6. AM-48 Keyboard Identification Numbers

① **16-Key Array.** The function of the keys depends on the positions of Switch 7 and Switch 12 (Figure 3-5). See Table 7-1.

To use the keys to dial MF, DTMF, or pulse, set Switches 7 and 12 as shown in Table 7-6. See Table 7-7 for a list of the dual tones for the different keys.

With Switch 7 in <SHIFT>, the number keys can enter new parameter values (§7.8), or momentarily send user-programmed tones from the QUIET SEND display (§7.13). The auxiliary functions of the other keys are described next.

②③ [ETR/NEXT], [ETR/PREV]. These keys have a dual function:

- A. To enter new parameter values into memory.
- B. To scroll through multiple displays.

After using the number keys to input a new parameter value:

- 1) Press either [ETR/NEXT] or [ETR/PREV] to enter the new value into memory.
- 2) Then press [ETR/NEXT] to step to the next display, or press [ETR/PREV] to step to the previous display.

If no change was made to the display, or a change was made with the [ ] or [ ] keys, press [ETR/NEXT or [ETR/PREV] once to go immediately to the next/previous display. See ¶7.8 for complete details.

④ [CANCEL]. Press [CANCEL] to erase a value input with the number keys. The display defaults to the previous value. To erase an input, press [CANCEL] before pressing [ETR/NEXT] or [ETR/PREV]. [CANCEL] does not operate after pressing [ ] or [ ] to change a value. See ¶7.8 for complete details.

⑤ [±]. This key is used to designate a positive or negative polarity for a new parameter value input with the number keys. See ¶7.8 for complete details.

**6** **9** [ **START** ], [ **STOP** ]. These keys are used in the IMPLS (impulse noise) and TRANS (transients, i.e., impulse noise, phase hits, gain hits, and dropouts) modes to stop/start the timed test. See ¶7.24 for information on timed tests. The [ **START** ][ **STOP** ] functions are in operation only when data is displayed, i.e., not when a user-entered parameter is displayed. With a user-entered parameter displayed, these same keys take on the functions explained for number 7 and 8.

**7** **8** [ ] / [ ]. Press [ ] or [ ] to step the value of any variable number displayed either up or down. Hold down [ ] or [ ] for one (1) second to enable auto-repeat mode and step in increments ten (10) times the normal increments. See Table 7-2 for the values of the increments, depending on the parameter.

### 3.7 Display

Figure 3-7 shows the AM-48 liquid crystal display:

1. The top line in Figure 3-7 shows all the possible units of measurement. The units of measurement appear as appropriate to label the value(s) displayed in the main display field. Time and Count parameters do not show the units on the display.
2. The main display field has nine (9) 7-segmented characters with decimal points. The prompts that appear on the display are "pseudo-alpha" because of the limitations of the 7-segmented characters. There are three (3) possible types of display fields, as explained in ¶7.4.
3. Below the main display field are the menus for the three (3) cursors, shown in detail in Table 3-2.

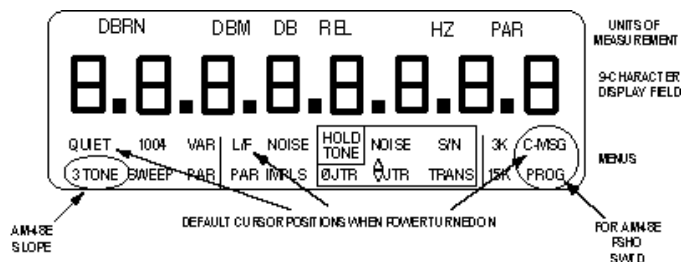

Figure 3-7. AM-48 Liquid Crystal Display

Menus. Table 3-2 defines each possible cursor position for the three (3) menus. The positions of the three (3) cursors identify the present SEND mode, MEASURE mode, and FILTER selected. Switches 4, 5, and 6 move the cursors to select the desired mode of operation.

Menu Color Coding and Framing.

1. All send modes on the SEND menu are yellow.
2. All noise-weighting filter options on the FILTER menu are orange.
3. On the MEASURE menu, both NOISE modes, IMPLS, S/N, and TRANS are orange, indicating that these measurements require a noise-weighting filter.
4. All MEASURE modes within the pink rectangle require a nominal 1004 Hz holding tone. The HOLD TONE indicator in the corner of the rectangle darkens when a valid holding tone is present at the receive port.

See Table 7-5 for a summary of measurement requirements.

**Note:** Throughout this manual cursor positions are referred to with ALL CAPITAL LETTERS, underlined. For example, QUIET always refers to the Quiet SEND menu cursor position and associated Quiet mode.

The SEND menu is yellow, the MEASURE menu is pink and orange, and the FILTER menu is orange.

Table 3-2. AM-48 SEND, MEASURE, and FILTER Menus

SEND MODES		MEASURE MODES		FILTER OPTIONS	
<u>QUIET</u>	Passive Resistor Termination	<u>L/F</u>	Level/Frequency	<u>3K</u>	3 kHz
<u>1004</u>	1004 Hz Tone @Selected Level	<u>NOISE</u>	Idle Channel Noise	<u>15K</u>	15 kHz
<u>VAR</u>	Variable Continuous Frequency @Level	<u>P/R</u>	Peak-to-Average Ratio with Receive Level	AM48 ONLY:	
AM48 ONLY:		<u>IMPLS</u>	Impulse Noise (Timed Test)	<u>C-MSG</u>	C-Message
<u>3TONE</u>	404 Hz, 1004 Hz, 2004 Hz for 5 sec. Cyclic @Selected Level	MEASURE MODES LISTED BELOW NEED 1004 HZ HOLDTONE		<u>PRG</u>	Program
AM48 ONLY:		<u>NOISE</u>	Notched Noise	AM48 ONLY:	
<u>SLOPE</u>	404 Hz, 1004 Hz, 2004 Hz, 3004 Hz for 5 sec. Cyclic @Selected Level	<u>S/N</u>	Signal-to-Noise Ratio	<u>PSHD</u>	Psophometric
AM48 ONLY:		<u>∅ JTR</u>	Phase Jitter	<u>SWTD</u>	Sound-Weighted
<u>SWEEP</u>	Tones Stepped per Selected Level, Start/Stop Frequencies, Step Size and Sweep Rate	<u>± JTR</u>	Amplitude Jitter		
<u>P/R</u>	Peak-to-Average Ratio Waveform @Selected Level	<u>TRANS</u>	Transients (Timed Tests): Impulse Noise, Phase Hits, Gain Hits, Dropouts		

### 3.8 Microphone/Speaker

The speaker is for "listening" on the send or receive pairs, and the microphone is for "talking" on the send pair. See ¶7.38.

Pressing Switch 14 to <TALK> (momentary position) activates the microphone.

Switches 3 and 14 control the speaker/earphone monitoring point. See Figure 9-1 for a block diagram showing the interaction of these switches. When Switch 3 is set to <DAMP>, the monitor point is after the auto-range amplifier which significantly increases the speaker level. This is particularly useful for audibly monitoring the residual noise in notched noise and S/N Ratio measurements.

### 3.9 Hand-Held Printer

The AM-47 Hand-Held Printer is designed to be used exclusively with the AM-48 to produce a hard copy of measurements and setups. Table 3-3 lists technical specifications, Figures 3-8 and 3-9 provide component locations, Figure 6-3 shows the connectors, and ¶7.39 contains the operating instructions.

Connectors. The connectors are used with the AC Adapter (70-0029) and the Printer Cable (48-0079) as shown in Figure 6-3. The AC Adapter is supplied with the AM-48, and the 48-0079 Printer Cable is supplied with the AM-47 Hand-Held Printer. The input is a special serial ASCII current loop compatible with the AM-48.

Power. Power is provided by an internal NiCad battery pack. When the printer is connected, power to the AM-48 comes from the printer battery pack, prolonging the life of the AM-48 batteries. There is an internal recharging circuit in the printer that operates when the AC Adapter is plugged in.

Power Switch. The slide switch to the left of the connectors is for POWER ON/OFF.

LEDs. The LEDs light as described below:

1. The POWER LED lights continuously when the AC Adapter is connected and the battery pack is charging (starts charge cycle each time power is turned ON).

AM-48 Test Set

(18-0015)

Unit Description

2. The POWER LED blinks when power is ON and the battery pack has been charged.
3. The SIGNAL LED lights when data is being received from the AM-48.

Printing Mechanism. The printing mechanism is a dot matrix impact type with a replaceable ribbon cartridge. It uses standard-width adding machine paper. The ribbon cartridge and paper supply are housed within the case (see Figure 3-9). The printout is in a 24-column format (see Figure 7-11 thru 7-13 for example printouts). In order to conserve paper, no automatic space is made after a printout. The paper can be advanced manually with the PAPER ADVANCE button.

Table 3-3. AM-47 Hand-Held Printer Technical Specifications

CHARACTERISTICS	SPECIFICATIONS
Input Signal	Serial ASCII Code with 2-Wire Proprietary Current Loop
Input Connector	4-Wide Modular Jack
Input Speed	300 Baud with 1500 Character FIFO Buffer
Print Type	6 x 8 Impact Dot Matrix
Paper	2.25"W x 1.8" Dia. Adding Machine Paper
Ink Supply	Replaceable Inked Ribbon Cartridge
Characters per Line	24
Print Speed	0.7 Lines per Second
Power	Internal NiCad Battery Pack with Built-In Charger
Battery Life	Approximately 10,000 Lines
Charge Time	8 to 14 Hours
Size	7.6"L x 3.4"W x 1.9"D
Weight	1.5 lbs.
Cables	Printer Cable (48-0079), Supplied AC Adapter (70-0029) (cables shown in Figures 3-3 & 3-4).

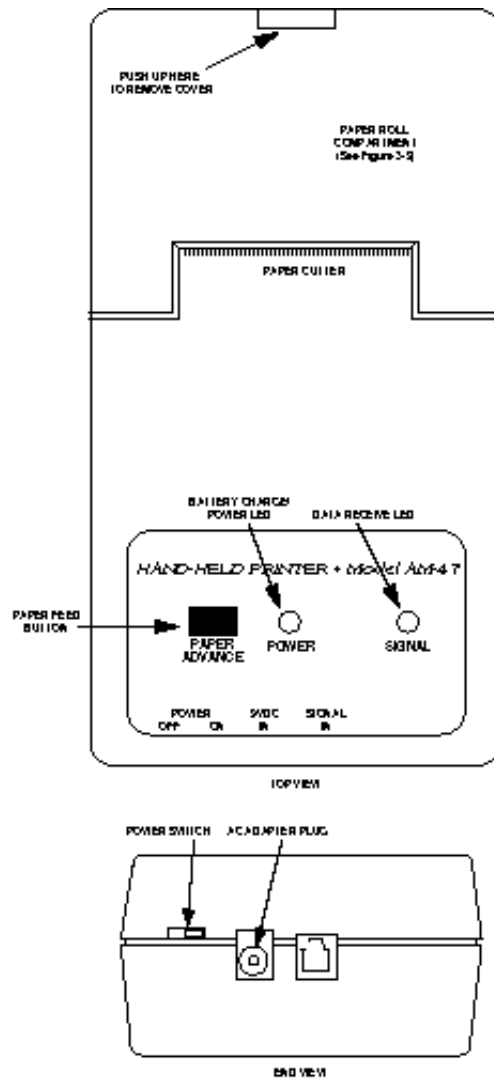

Figure 3-8. Hand-Held Printer, External View



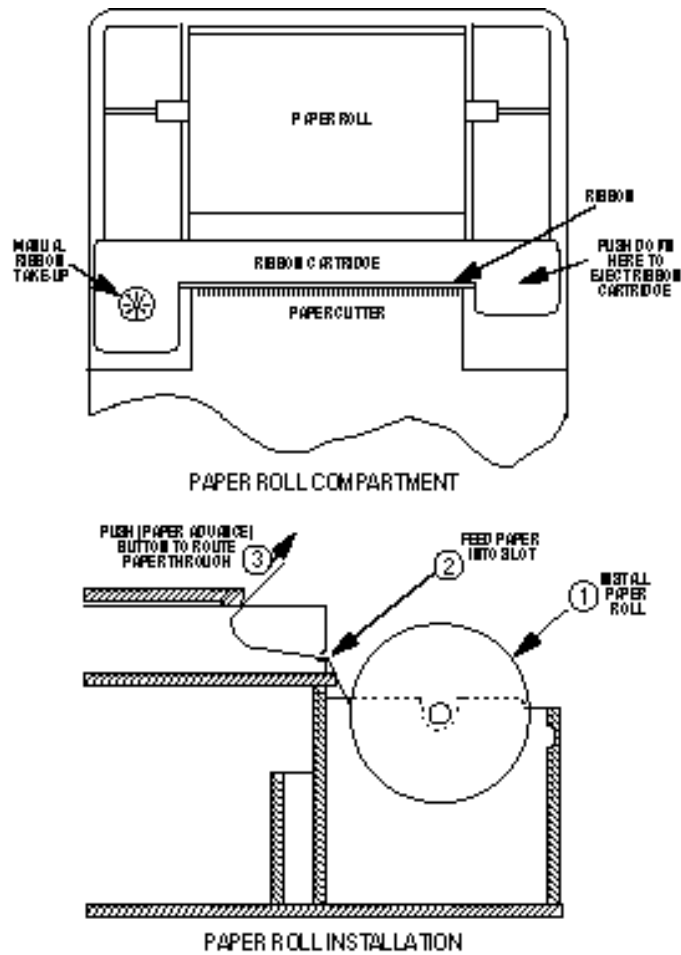

Figure 3-9. Hand-Held Printer, Internal View

### 3.10 Impedance Adapter

The Impedance Adapter (24-0005) is illustrated in Figure 3-10. It is used to match the AM-48 to:

1. Line impedance other than 600 Ohms or 900 Ohms
2. 4-Wire split impedances

The Impedance Adapter has settings for five (5) different impedances to match the AM-48 to the user interface. It plugs into the RJ11 modular connector of the AM-48. See ¶6.5 for installation, and ¶7.41 for measurement corrections when the Impedance Adapter is used. The schematic of the Impedance Adapter is shown in Figure 9-2.

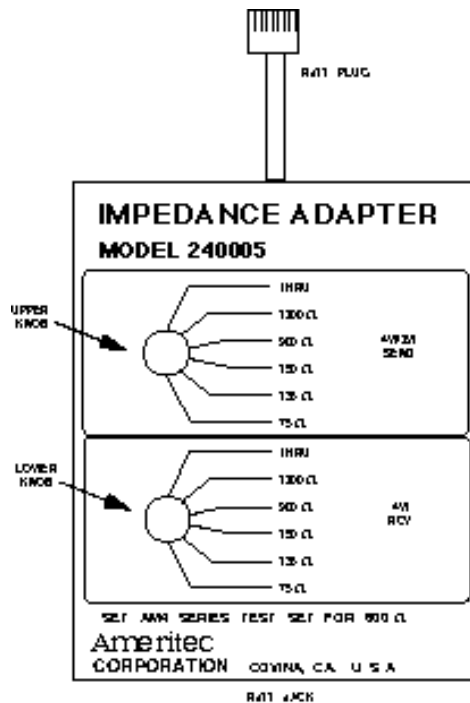

Figure 3-10. Impedance Adapter

## 4 POWER CONSIDERATIONS

### 4.1 General

This section covers AM-48 power considerations, including battery installation, AC Adapter connection, and the power on/off switch.

The AM-48 runs on internal battery or external AC power. Flashing display decimal points indicate low batteries; alkaline batteries need replacing, and NiCad batteries need recharging.

Low-Level Noise Measurements. Power the AM-48 with batteries when making a low-level noise measurement. Do not power the AM-48 with the AC Adapter for this test, because interference from the AC source can affect the measurement.

### 4.2 Battery Compartment

The battery compartment under the rear panel is accessed through a removable slide door. The compartment takes four (4) AA 1.5-volt alkaline or NiCad batteries. The battery compartment also serves as a recharger for NiCad batteries when the AM-48 is connected to 115 VAC with the AC Adapter.

### 4.3 Battery-Selector Switch

The Battery-Selector Switch is on the inside edge of the battery compartment as shown in Figure 4-1.

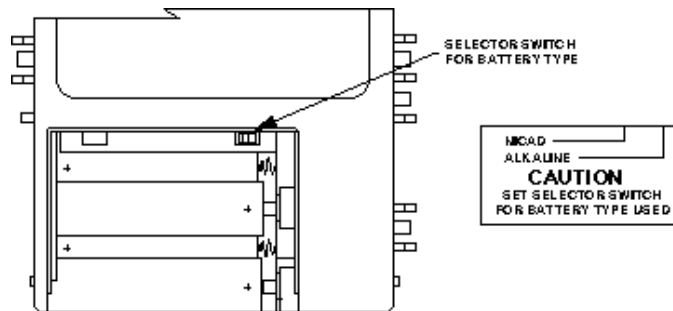

Figure 4-1. Battery Installation and Selector Switch

Using a pointed instrument, such as a pencil, set the Battery-Selector Switch to “NICAD” or “ALKALINE” position to match the type of battery used.

**NICAD Position.** This position connects the internal battery charge circuitry to charge the NiCad batteries when the AC Adapter is connected. Never set the switch to this position when using alkaline batteries.

**ALKALINE Position.** The internal battery charge circuitry is disconnected because alkaline batteries are not rechargeable.

**WARNING:** The Battery-Selector Switch **MUST** be in the “ALKALINE” position when using alkaline batteries. Alkaline batteries can explode if the AC Adapter is used with alkaline batteries with the Battery-Selector Switch in the “NICAD” position; warranty is voided if this happens.

## 4.4 Battery Installation

To install the batteries:

1. Slide off the battery compartment cover.
2. Set the Battery-Selector Switch per ¶4.3.
3. Lay the ribbon in the base of the compartment (to be able to pull up on the ribbon for easy removal of the batteries).
4. Install four (4) 1.5-volt AA NiCad or Alkaline batteries as shown in Figure 4-1.
5. Replace the battery compartment cover.

## 4.5 Battery Information

General. When new, each battery will furnish approximately 1.5 Volts. The batteries are wired in series, supplying 6 VDC nominal. An internal DC-to-DC Converter allows operation until the batteries have discharged to approximately 3 Volts.

To avoid battery chemical leakage:

1. Use only first quality batteries
2. Do not subject the AM-48 to excessively high temperatures.

The warranty does not cover damage resulting from battery leakage.

Alkaline Batteries. The AM-48 is shipped with four (4) high-quality alkaline batteries, which give approximately 6-7 hours of service. When the batteries have discharged to approximately 3.5 volts, the display decimal points will flash. The flashing indicates approximately 30 minutes of remaining operating life.

NiCad Batteries. Commercially available AA size Nickel Cadmium (rechargeable) batteries can be used, but operating life will be reduced to approximately 3 to 4 hours because of the limited energy storage capacity of rechargeable batteries. Due to the abrupt end-of-life discharge curve of Nickel Cadmium batteries, the flashing decimal points low-battery indication will only provide a few minutes of warning before the end of operation.

## 4.6 AC Power

To power the AM-48 with 115 VAC, plug one end of the AC Adapter (70-0029) into the <DC 9V> connector on the bottom of the unit, and the other end into an AC wall jack. See Figure 3-3 for the AC Adapter, and Figure 3-2 for the AC Adapter plug on the AM-48.

The AC Adapter supplies 9 VDC to the AM-48. The locations of the + and – DC voltage contacts on the 2.5 mm jack of the AC Adapter are illustrated on the transformer housing of the AC Adapter itself.

When using the AM-47 Hand-Held Printer, the AC Adapter can be used to maintain the charge of the printer batteries that power the AM-48. See Figure 6-3 for connections.

## 4.7 Power On/Off Switch

The Power On/Off Switch is a combination toggle switch and momentary switch located at the top right-hand side of the AM-48 (Switch 1 in Figure 3-5).

Automatic Power Shutdown. To allow the AM-48 to power down by itself, momentarily press the switch toward the <ON/OFF> position to turn the power on. If the unit is left unattended, the power will shut off automatically after the TIME OFF setting (see ¶7.12.4 for instructions to set the time).

Continuous Power On. Set the switch to the <ON> position for power to be on continuously.

**Note:** To turn power on continuously when battery voltage is less than about 5 VDC, first turn power ON in momentary <ON/OFF> position, then set switch to <ON>.

Power Off. To turn the power off, momentarily press the switch toward the <ON/OFF> position.

The position of Switch 2 determines the initial display. The default power-up cursor positions are shown in Figure 3-7.

Power Considerations

(18-0015)

AM-48 Test Set



## 5 SELF-TEST INSTRUCTIONS

### 5.1 General

Purpose. This section has two (2) objectives:

1. To practice the main AM-48 operating procedures.
2. To verify that the AM-48 is working properly.

General. Each test in this section is described and illustrated. In the figures, circled letters correspond to the steps of the written description; circled numbers identify the switches.

**Note:** Power is ON for the tests in this section. See Section 4 concerning connecting and turning on power to the AM-48.

### 5.2 Self-Test Setup

Self-Test Setup is depicted in Figures 5-1 and 5-2.

Cable Connection. The tests in this section are done with the AM-48 looped back on itself, not connected to any external equipment. Plug in the Modular-to-Minigator Cable (48-0049) (supplied with the AM-48), and connect the minigator clips as shown in Figure 5-1. The signals sent (generated) through the send port are routed directly back to the receive port.

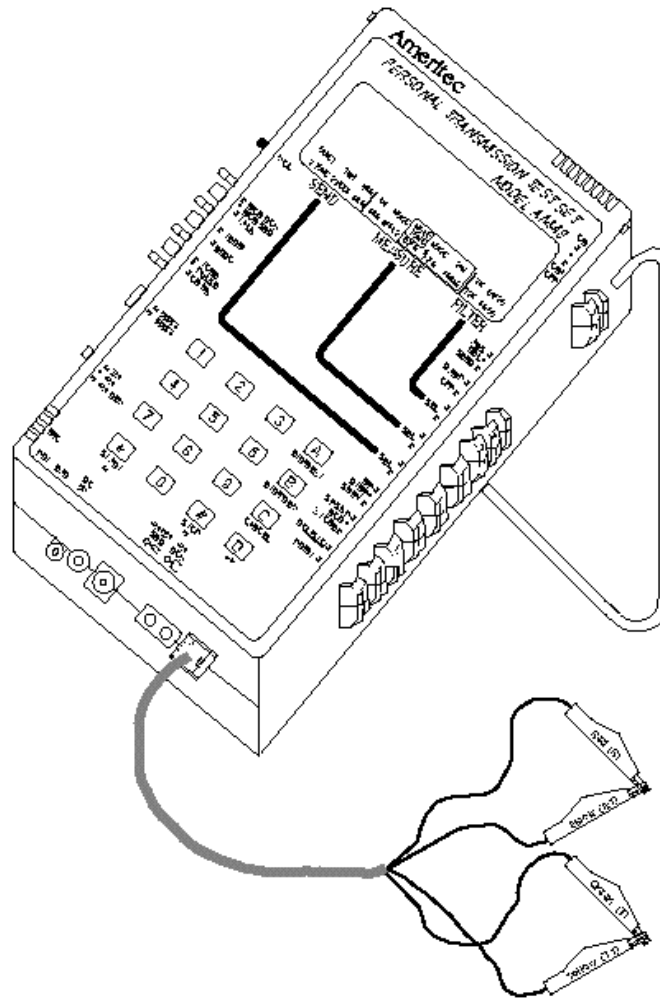

Figure 5-1. AM-48 Setup for Self-Test (Looped Back)

General Switch Setup. Figure 5-2 shows the initial positions of the switches for the tests in this section. Leave these switches in the positions indicated unless otherwise directed in the instructions for the individual tests. Switches are referenced by the circled numbers.

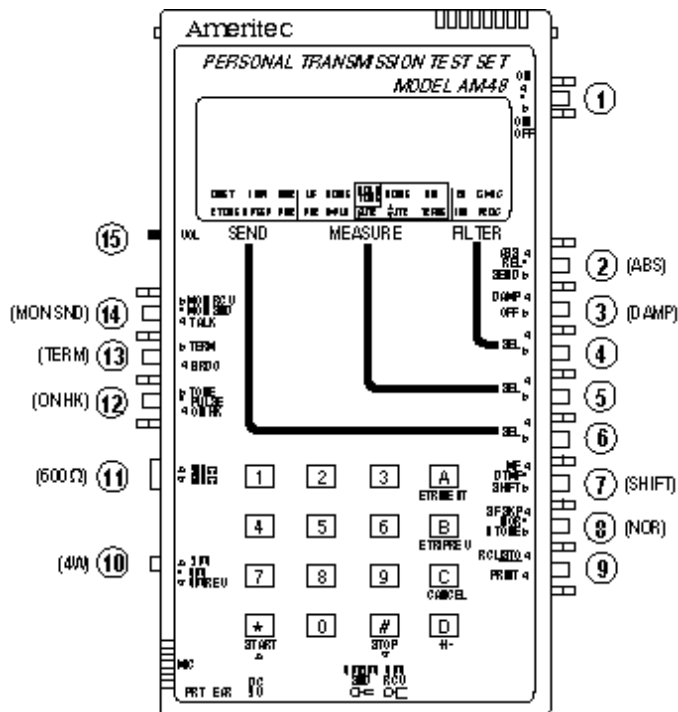

Figure 5-2. General Switch Setup for Self Test

Switches 4, 5, 6, and 9 do not have a set position because they are all dual momentary switches. The instructions for each test will indicate when to rock switches 5 and 6 to move the cursors to desired positions on the display menus.

The FILTER menu cursor (controlled by Switch 4) will default to C-MSG (PSHO for AM-48E) when power is turned on. Leave the cursor in this position for all the tests in this section.

### 5.3 Quiet Send Mode

Quiet Send Mode switch settings and display are depicted in Figure 5-3.

- A. Verify that the SEND menu cursor is in QUIET (default position when power is first turned on). Rock Switch 6 if necessary to move cursor to QUIET.
- B. Verify that the MEASURE menu cursor is in L/F (default position when power is first turned on). Rock Switch 5 if necessary to move cursor to L/F (level/frequency).
- C. Display should read “UNDR” with units “DBM” and “HZ”.
- D. Rock Switch 5 to move cursor to NOISE (to the right of L/F).
- E. Display should read “UNDR” with units of “DBRN” (“DBM” for AM-48E).

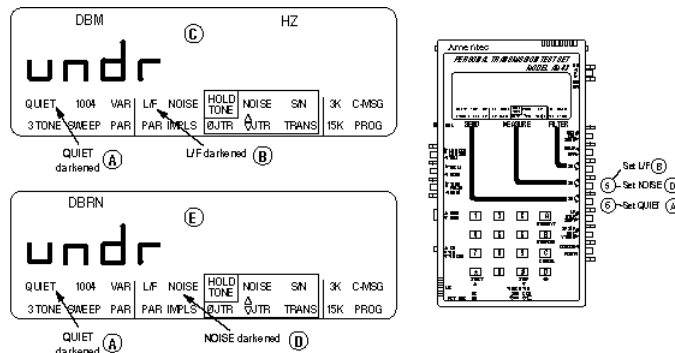

Figure 5-3. Quiet Send Mode Self Test

## 5.4 Send 1004 Hz

Send 1004 Hz switch settings are depicted in Figure 5-4, while the displays are depicted in Figure 5-5.

- A. Rock Switch 6 to move SEND menu cursor to 1004.

**Note:** Turn volume control (“Switch” 15) up or down as desired to increase or decrease the volume of the speaker sound. With Switch 14 in <MON SND>, the speaker is monitoring the 1004 Hz tone being sent.

- B. Rock Switch 5 if needed to move MEASURE menu cursor to L/F.  
C. Read “00.0 ±0.1 DBM” and “1004 HZ” on display.  
D. Rock Switch 5 to move MEASURE menu cursor to NOISE.  
E. Read “90.0 ±1.0 DBRN” (“00.0 ±1.0 DBM” for AM-48E) on display.  
F. Rock Switch 5 to move MEASURE menu cursor to NOISE (to the right of HOLD TONE).

**Note:** HOLD TONE will be darkened for the remaining steps in this paragraph.

- G. Read typically “32.0 DBRN” (must be <40.0 dBm) and “1004 HZ” on display; for AM-48E, “-58.0 DBM” (must be <-50.0 dBm).  
H. Rock Switch 5 to move MEASURE menu cursor to S/N (signal-to-noise ratio).  
I. Read typically “58.0 DB” (must be >50.0 dB) and “1004 HZ” on display.  
J. Rock Switch 5 to move MEASURE menu cursor to ∅ JTR.  
K. Read “JTR 00.0 ±0.2” on display.  
L. Rock Switch 5 to move MEASURE menu cursor to \_ JTR.  
M. Read “JTR 00.0 ±0.2” on display.

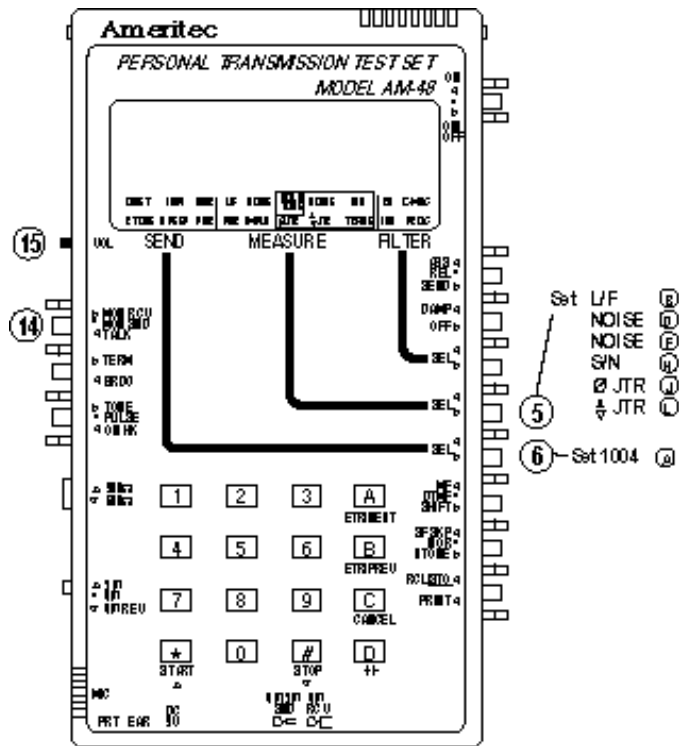

Figure 5-4. Send 1004 Hz Self Test, Switch Settings

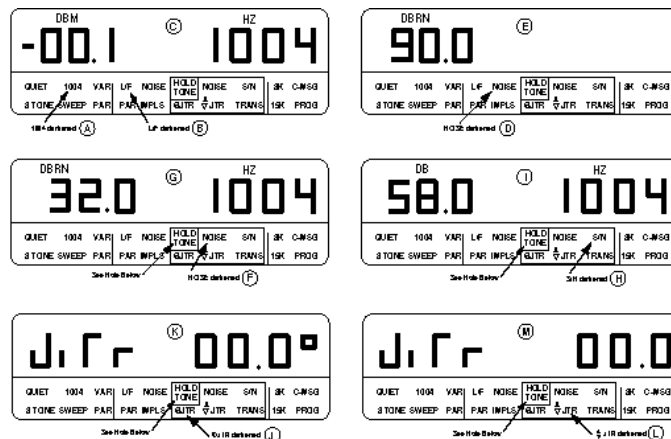

Figure 5-5. Send 1004 Hz Self Test, Displays

**Note:** HOLD TONE is darkened for all measurements with MEASURE menu cursor inside the pink rectangle.

1004 is darkened for all tests in Figure 5-5.

## 5.5 Send PAR (Peak-to-Average Ratio)

Send PAR switch settings and display are depicted in Figure 5-6.

- A. Rock Switch 6 to move SEND menu cursor to PAR.

**Note:** Turn volume control (“Switch” 15) up or down as desired to increase or decrease the volume of the speaker sound. With Switch 14 in <MON SND>, the speaker is monitoring the PAR waveform being sent.

- B. Rock Switch 5 to move MEASURE menu cursor to PAR.
- C. Read “00.0 ±1.0 DBM    100 ±2 PAR” on display.

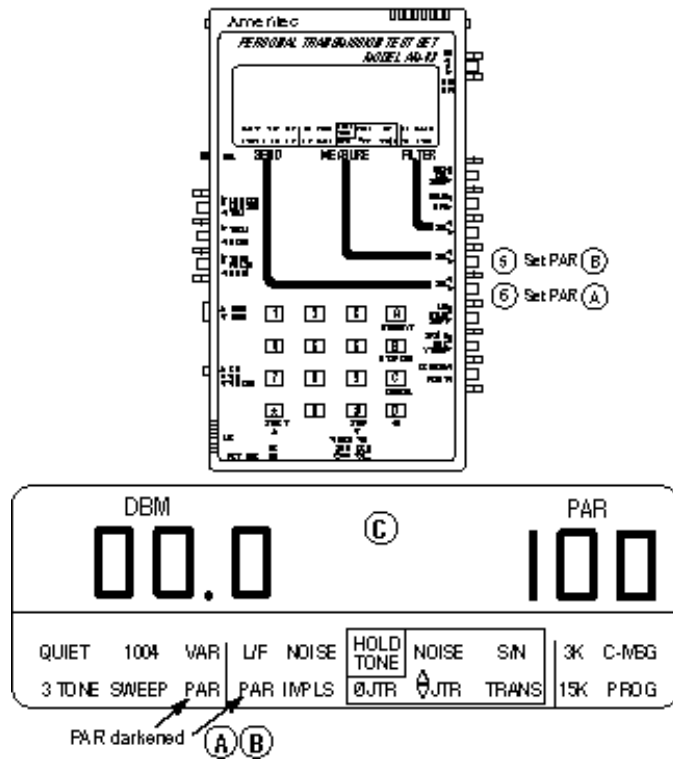

Figure 5-6. Send PAR (Peak-to-Average Ratio)

## 5.6 Dialing

Dialing switch settings and display are depicted in Figure 5-7.

- Rock Switch 6 to move SEND menu cursor to QUIET.
- Rock Switch 5 to move MEASURE menu cursor to L/F.
- Set Switch 2 (display select) to <SEND>.
- Set Switch 7 to <MF>.
- Set Switch 12 to <TONE>.



- F. Turn volume control (“Switch” 15) all the way up for maximum speaker volume.
- G. Press various keys on the keypad to dial MF (multiple frequency) tones. Listen to the dual tones coming from the speaker. The speaker will emit the tones as long as the key is held down. Note that key [D] has no MF tones.

**Note:** See Table 7-7 for list of dual frequencies transmitted in tone dialing.

- H. When doing step G., the display will read “DIAL -10.0 DBM”. This indicates that -10.0 dBm (factory setting) is the send level. Tone dialing send level can be changed. See ¶7.12.3 and Figure 7-1 for “TTLEV” (Touch Tone Level) display.
- I. Set Switch 7 to <DTMF>.
- J. Press various keys on the keypad to dial DTMF (Dual Tone Multiple Frequency) tones. Listen to the dual tones coming from the speaker. The speaker will emit the tones as long as the key is held down.
- K. The display will read as in step H.
- L. Set Switch 12 to <PULSE>.
- M. Press the keys on the keypad and note that no sound is heard. No battery is connected to the line and line battery voltage is required for pulse dialing.

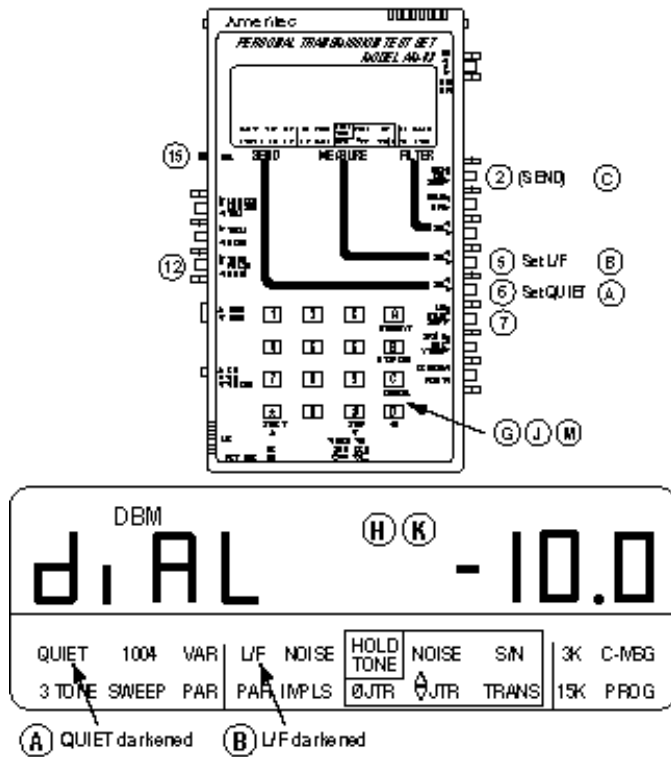

Figure 5-7. Dialing

## 5.7 Parameter Values for Send Sweep

Parameter Values for Send Sweep settings and display are depicted in Figure 5-8.

- Set Switch 2 to <SEND>.
- Set Switch 7 to <SHIFT>.
- Rock Switch 6 to move SEND menu cursor to SWEEP.

**Note:** The MEASURE menu cursor can be in any mode.

Turn volume control (“Switch” 15) up or down as desired to increase or decrease the volume of the speaker sound. With Switch 14 in <MON SND>, the speaker is monitoring the frequencies being swept.

- D. Display will read “00.0 DBM” and frequencies which start at “204 HZ” and increase in 100 Hz steps every second up to 19,904 Hz, at which time the sweep starts again at 204 Hz.
- E. Rock Switch 6 once to momentarily exit SWEEP mode. Rock Switch 6 once in the opposite direction to re-enter SWEEP mode (SEND menu cursor back to SWEEP). Note that the sweep starts again at 204 Hz.
- F. Press [ETR/NEXT] on the keypad ([A] key).
- G. Display will change to “LEVL 00.0 DBM”. This is the first of the five (5) default parameter settings shown in Figure 5-8.
- H. Repeat Step F. four (4) more times and observe the NEXT displays in sequence:
  - I. “STRT 204 HZ”
  - J. “STOP 19904 HZ”
  - K. “STEP 100 HZ”
  - L. “RATE 1.0”
- M. Press [ETR/PREV] on the keypad ([B] key) five (5) times and observe the PREVIOUS displays appear in reverse sequence.

**Note:** In the remaining steps, an example will be given of setting new parameter values for the SWEEP mode. Carefully note the procedure, because the same procedure is used for setting all AM-48 parameter values.

- N. Repeat Step E. to start with the first SWEEP display.
- O. Press [ETR/NEXT] to go to the NEXT display (sweep frequency LEVEL).
- P. Press [ $\pm$ ], same as [D] key. Then press [5] and [0]. Display now reads "LEVEL -5.0 DBM". Press [ $\pm$ ] several times and notice the "" sign appear and disappear. Leave display with the "".
- Q. Press [ETR/NEXT] again. This enters the new LEVEL, -5.0 dBm.
- R. Press [ETR/NEXT] to go to the NEXT display (START frequency setting).
- S. Press [4], [0], [0]. Display now reads "STRT 400 HZ".
- T. Press [ETR/NEXT] again. This enters the new START frequency, 400 Hz.
- U. Press [ETR/NEXT] to go to the NEXT display (STOP frequency setting).
- V. Press [1], [6], [0], [0]. Display now reads "STOP 1600 HZ".
- W. Press [ETR/NEXT] again. This enters the new STOP frequency, 1600 Hz.
- X. Press [ETR/NEXT] to go to the NEXT display (frequency STEP setting).
- Y. Display now reads "STEP 100 HZ".

**Note:** In the next step, a "mistake" will be made when entering a new parameter value to show how it can be corrected.

- Z. Press [2], [0], [0]. Display now reads "STEP 200 HZ". This is a mistake; desired step is actually 300 Hz.
- AA. Press [CANCEL], same as [C] key. The incorrect value is gone and the display now reads as in Step Y.
- BB. Press [3], [0], [0]. Display now reads "STEP 300 HZ", the desired value.

- CC. Press [ETR/NEXT] again. This enters the new frequency STEP, 300 Hz.
- DD. Press [ETR/NEXT] to go to the NEXT display (RATE, i.e. duration of each frequency in the sweep).
- EE. Display now reads "RATE 1.0".
- FF. Press [ ] momentarily repeatedly and notice the time increase 0.1 sec at a time: 1.1, 1.2, 1.3. ....sec. Hold [ ] down continuously and notice that the time starts increasing in steps of 1.0 sec; 2.0, 3.0, 4.0, ....sec. Press momentarily and/or hold down [ ] and note that the time decreases in steps of 0.1 and/or 1.0 sec. Use [ ] and [ ] as necessary to step the time (rate) to 2.0 sec.
- GG. Display now reads "RATE 2.0".
- HH. Press [ETR/NEXT] to return to the original display. Instead of the sweep that was seen in Step D., there is now a new sweep that reflects the settings just entered. Display now reads "-05.0 DBM" and shows frequencies which start at "400 HZ" and increase in 300 Hz steps every 2 seconds up to 1600 Hz, at which time the sweep starts again at 400 Hz.

**Note:** The new parameter settings will remain until (1) they are changed, or (2) power is turned off. If power is turned off, the settings will revert back to the default settings as shown in Figure 5-8.

This completes the self test. See Section 7 for complete operating instructions and details of other tests and parameter settings not covered here.

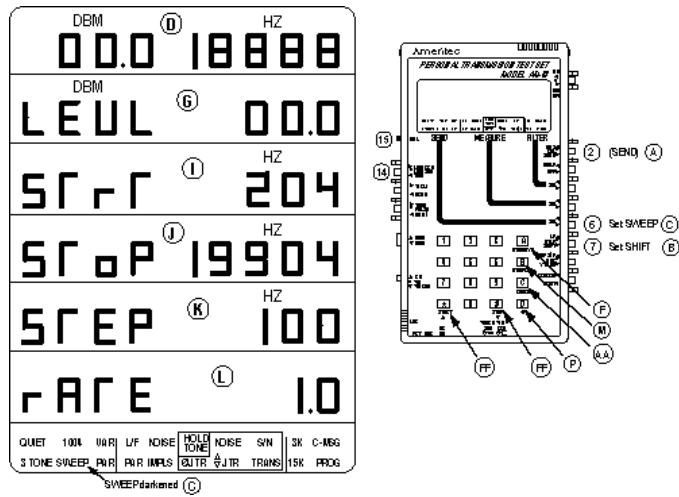

Figure 5-8. Default Parameter Settings for SWEEP Send Mode

## 6. CONNECTION AND CONFIGURATION

### 6.1 Introduction

This section describes the AM-48 connections and configurations made in preparation for testing. It is divided into the following paragraphs:

- 6.2 General
- 6.3 Connectors and Cables
- 6.4 600 Ohm/900 Ohm Line Termination Impedances
- 6.5 Impedance Adapter
- 6.6 Configurations

In ¶6.6, basic operating instructions are given for testing with the Western Electric 829 loopback device, as well as with Ameritec responders.

**Note:** Section 7 gives detailed AM-48 operating instructions and Section 8 explains the meaning of the measurements.

### 6.2 General

Low-Level Noise Measurements. Power the AM-48 with batteries when making a low-level noise measurement. Do not power the AM-48 with the AC Adapter for this test because interference from the AC source can affect the measurement.

“Dry” Circuit Measurements. Set Switch 12 (Figure 3-5) to <ON HK> when making measurements on “dry” (4-wire only) circuits. “Dry” circuits have no loop current.

Independent Send and Measure Modes. The Send, Measure, and Filter modes of the AM-48 operate completely independently. Any combination of Send, Measure, or Filter can be selected. However, depending on the setup, the resulting measurements may or may not be valid.

For example, a 1004 Hz holding tone must be sent for various measure modes and a PAR waveform must be sent when PAR is measured. If the 1004 Hz tone or PAR waveform were not present in the corresponding measurement, the measurement would not be valid. The AM-48 configuration (see ¶6.6) determines in what part of the system the signals need to be sent and measured.

The correct Send, Measure, and Filter modes are indicated for each test described in the operating instructions of Sections 5 and 7.

## 6.3 Connectors and Cables

See Figures 3-2 thru 3-4 for illustrations of the AM-48 connectors and cables. Note that some cables are standard and others are optional. Connect the appropriate cable(s) described in this paragraph according to the desired application.

AC Adapter. Connect the circular connector of the AC Adapter to the <DC 9V> AC Adapter Plug. Plug the two (2) prongs on the other end into a standard 115 VAC wall socket. Observe the WARNING in ¶4.3.

Earphone. The earphone can be used in place of the speaker. Use the earphone to hear better in noisy environments or to listen without disturbing other people in the area. See the WARNING in ¶3.5.15 before connecting the earphone. Plug the earphone into the <EAR> Earphone Jack. Note that the internal speaker is disconnected when the Earphone is plugged in.



Printer Cables. There are two (2) types of cables used with printers. The 48-0079 is used with the AM-47 Hand-Held Printer. The 48-0078 is used to connect with most other 25-pin female serial EIA printers. The pin assignments of the male connector are:

- 2 = RCV
- 3 = XMIT
- 7 = GND
- 20 = Data Terminal Ready (+12V typical)

Figure 6-3 shows the connections for the AM-47 Hand-Held Printer. See ¶7.39 for operating instructions for printing.

Line Connection Cables. The RJ-11 (modular) and three (3) Bantam cables illustrated in Figures 3-4 and 3-5 are used for line connections. Use these cables as required to connect the AM-48 to 2-wire or 4-wire lines. Figures 6-1 and 6-2 illustrate and define Modular and Bantam line connections. Be sure to set Switch 10 (Figure 3-5) to the appropriate position as indicated in the Figures.

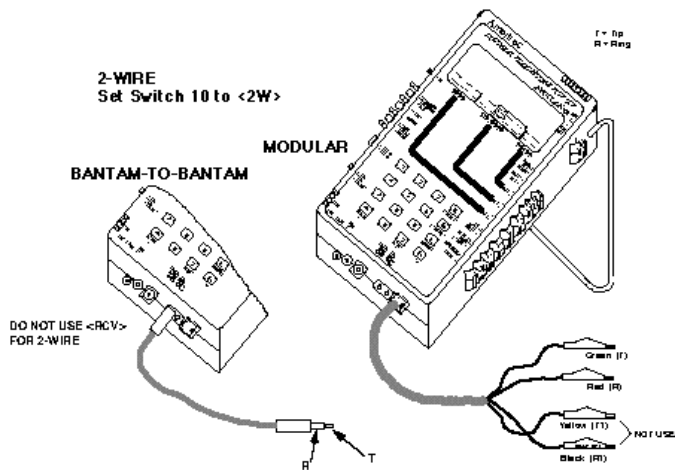

Figure 6-1. 2-Wire AM-48 Line Connections

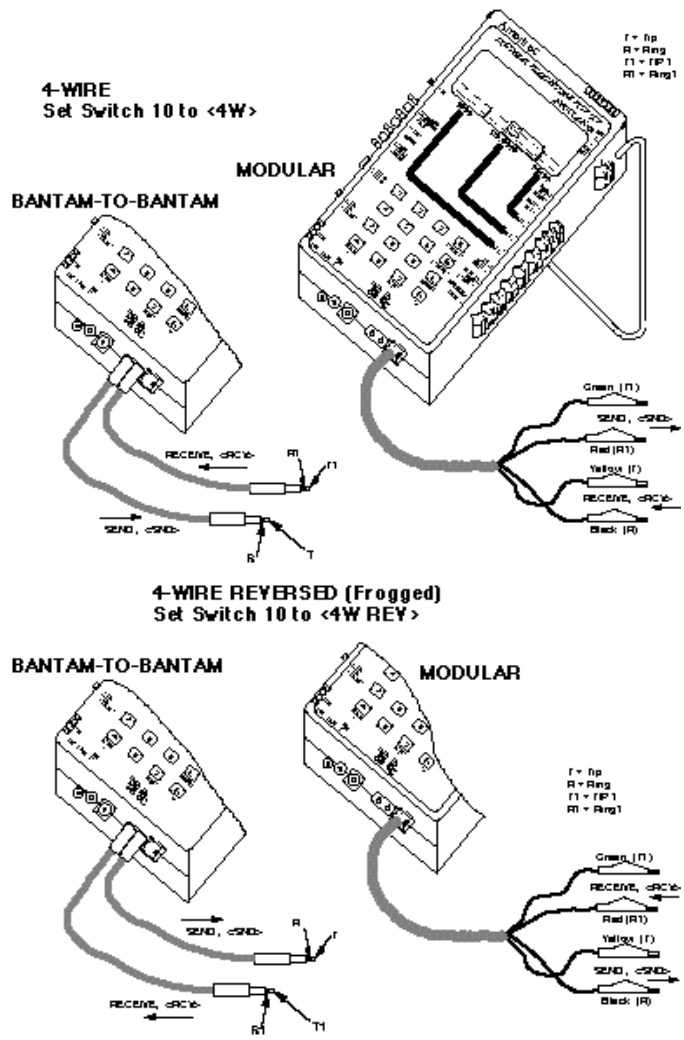

Figure 6-2. 4-Wire AM-48 Line Connections

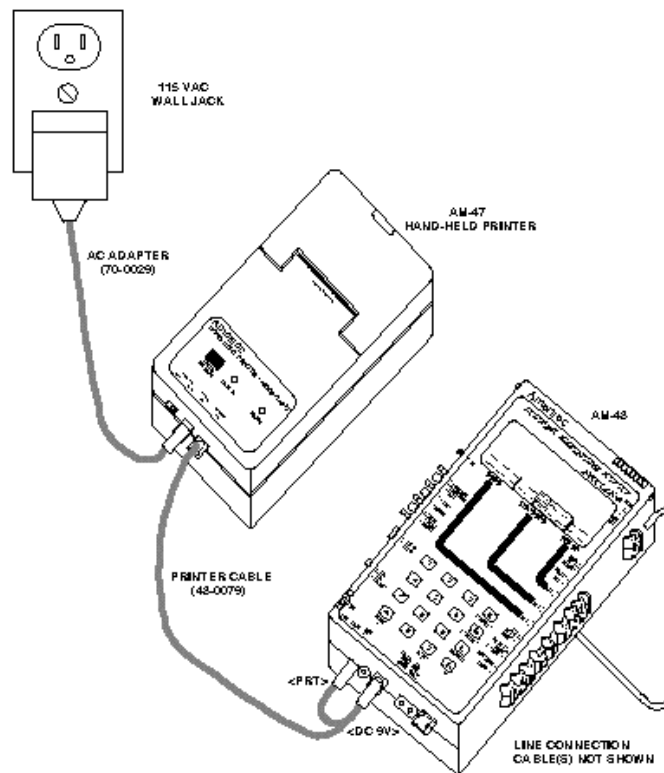

Figure 6-3. AM-47 Hand-Held Printer Connection with AC Power

**Note:** The RJ-11 and Bantam jacks are wired in parallel, resulting in an identical connection when either type of plug is used. Do not use the <RCV> jack to connect 2-wire lines.

AM-48 Interface with Line Connections. The position of Switch 10 (Figure 3-5) determines the connection of the AM-48 internal circuitry to the 2-wire or 4-wire lines. The connections for the different settings of Switch 10 are listed below:

<2W> Connects the internal measurement circuitry to the signal generator across the 2-wire line at the <SND> jack. The signal generator source impedance 600 or 900 (determined by Switch 11) terminates the line in all signal generator modes except QUIET. In QUIET mode, the line will be terminated only if Switch 13 is set to <TERM>. Note that the <RCV> jack is not used to connect to 2-wire lines.

<4W> Connects the internal measurement circuitry to the <RCV> pair, and the internal signal generator to the <SND> pair.

<4W REV> Send and receive pairs (as defined above) are reversed.

See ¶6.4 and 6.5 for details about line termination impedance.

AM-48 is Polarity Insensitive. It does not matter which way the Send pair or Receive pair of contacts are connected. The Send <SND> T and R can be interchanged without affecting the measurement. The Receive <RCV> T1 and R1 may also be switched without changing the measurement.

For example, in Figure 5-1, which shows the loopback connections for self-test, the connections could be changed as indicated below:

Figure 5-1 Connections	Alternate Connections
RED (R) to BLACK (R1)	RED (R) to YELLOW (T1)
GREEN (T) to YELLOW (T1)	GREEN (T) to BLACK (R1)

In general:

1. For 4-wire
  - a) Use the <SND> T and R (connecting either way) for the Send contacts
  - b) Use the <RCV> T1 and R1 (connecting either way) for the Receive contacts
2. For 2-wire, use <2W> T and R (connected either way). These contacts are the same as <SND> for 4-wire.

## 6.4 600 /900 Line Termination Impedances

It is important that the line(s) be properly terminated with a matching impedance. This paragraph gives instructions for terminating lines with 600 or 900 impedance. To terminate lines with impedance other than 600 or 900 connect the Ameritec Impedance Adapter as per ¶6.5.

To terminate the line(s) correctly with 600 or 900 :

1. Choose either terminate or bridge mode:
  - a) Set Switch 13 to <TERM>, terminate mode, or
  - b) Set Switch 13 to <BRDG>, bridge mode, and terminate the line with some other device (such as a modem) of proper impedance.
2. Regardless of the method of termination, set Switch 11 to <600 > or <900 > to match the impedance of the line.

**Note:** An incorrect Switch 11 setting results in about 1.8 dB error in level and noise readings.

Switch 13 Settings. The connections for the settings of Switch 13 are listed below:

- <TERM> Receive line terminated with a resistive impedance as selected by Switch 11.
- <BRDG> Receive line unterminated and bridged only with the impedance of the measurement circuitry (>25K  $\Omega$ ) across the receive pair.

**Note:** In 2-wire mode, the signal generator source impedance will terminate the line with 600  $\Omega$  or 900  $\Omega$  with Switch 13 in either <TERM> or <BRDG>. However, if SEND is in QUIET mode, Switch 13 will be able to function. In 2-wire QUIET send mode, setting Switch 13 to <BRDG> will disconnect the signal generator from the send pair and the send pair source impedance will be >25K  $\Omega$ . There will be an error of 6 dB if <BRDG> is incorrectly selected when the line should be terminated with <TERM>.

Switch 11 Settings. The connections for the settings of Switch 11 are listed below:

- <600 > 600  $\Omega$  applied across the Receive pair when Switch 13 is set to <TERM>.  
Send pair source impedance set at 600  $\Omega$ .
- <900 > 900  $\Omega$  applied across the Receive pair when Switch 13 is set to <TERM>.  
Send pair source impedance set at 900  $\Omega$ .

## 6.5 Impedance Adapter

The Impedance Adapter (24-0005) is used:

1. To match the AM-48 to a user interface of impedance other than 600 or 900.
2. To match 4-wire split impedances.

See Figure 3-10 for an illustration of the Impedance Adapter; Figure 9-2 is the schematic diagram of the Impedance Adapter.

The Impedance Adapter is used to adapt the AM-48 to impedances of 75  $\Omega$ , 135  $\Omega$ , 150  $\Omega$ , or 1200  $\Omega$ . For example, high speed digital lines typically have impedances of 75  $\Omega$ , 135  $\Omega$ , or 150  $\Omega$ . A "THRU" setting on the Impedance Adapter makes a straight through connection resulting in a 600  $\Omega$  or 900  $\Omega$  termination inside the AM-48.

To use the AM-48 with the Impedance Adapter:

1. Set AM-48 Switch 11 to <600  $\Omega$ > and Switch 13 to <BRDG>.
2. Plug the Impedance Adapter into the AM-48 modular jack.
3. Plug a modular line cable into the jack on the Impedance Adapter.
4. Connect the line cable to the 2-wire or 4-wire line per Figure 6-1 or 6-2.
5. Turn knob(s) on the Impedance Adapter to match the impedance of the line:
  - a) For 2-wire, use only the upper knob.
  - b) For 4-wire, set the upper knob to match the Send pair impedance and the lower knob to match the Receive pair impedance.

**Note:** The reading on the AM-48 display needs to be corrected when the Impedance Adapter is used; see ¶7.41 for instructions.

## 6.6 Configurations

There are three (3) basic AM-48 configurations to test 2-wire and 4-wire telephone and data communication lines:

1. End-to-end - requiring two (2) AM-48's
2. Loopback
3. Testing with responders

This paragraph describes the different configurations, explains how they are used, and discusses the advantages and disadvantages.

**Note:** End-to-end and responder testing applies to either 2-wire or 4-wire. Loopback testing only applies to 4-wire.

End-to-end Testing. Measurements on telephone transmission lines are usually made by applying an appropriate signal at one end of the transmission line and then measuring the results at the other end of the line. This configuration requires a test set at each end of the line and is called “end-to-end” testing.

Figure 6-4 shows a 4-wire end-to-end configuration, making measurements over a telephone network that normally connects two (2) modems. Each AM-48 both sends and receives signals, sending a signal over the <SND> pair of lines and measuring the signal received over the <RCV> pair of lines.

End-to-end testing can also be done over 2-wire lines. The AM-48 on one end sends a signal, and the AM-48 on the other end measures the received signal.



End-to-end testing is the most reliable for characterizing the near-to-far and far-to-near impairments, but it has the disadvantage of requiring two (2) test sets and an operator at each test site.

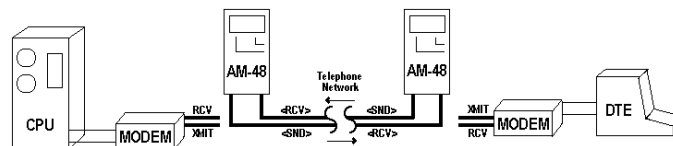

Figure 6-4. 4-Wire End-to-End Testing

**Loopback Testing.** The distant end of a 4-wire transmission line can be looped back (1) manually, or (2) with a commandable loopback device such as a Western Electric Model 829. The AM-48 at the near end sends a signal which travels to the distant end where it makes a U-turn and travels back to the AM-48, which measures the received signal.

The advantage of this configuration is that it requires only one (1) operator and test set at a central site. Although this method is more convenient and less costly than end-to-end testing, it is also less reliable. The disadvantage is that it does not characterize transmission impairments in each direction. Instead of detecting impairments, a loopback measurement could actually cover them up.

An apparently satisfactory loopback measurement may contain impairments in each direction which cancel each other. Loopback testing may be useful, providing its limitations are recognized.

**Note:** A loopback test can not be done on 2-wire because signals can not be sent and measured simultaneously on the same pair of lines.

To do a loopback test with a Western Electric Model 829:

1. Connect the AM-48 at the near end of the 4-wire line under test.

2. With Switch 8 (Figure 3-5), momentarily press <X TONE> to send a 2713 Hz tone over the <SND> line. This will trip the distant Model 829 into loopback.
3. Send the desired test signal with the AM-48 and make the desired measurement of the looped-back signal.
4. After testing is finished, momentarily press <X TONE> to restore the Model 829 to its normal, transparent state.

Testing with Responders. The use of multi-function responders supplies most of the advantages of end-to-end testing with the added advantage of not requiring an AM-48 at the far end of the system. This configuration is similar to loopback testing except that the responder can generate signals in addition to looping back. Unlike a dedicated loopback device, responders can be used in 2-wire far-to-near testing.

On 4-wire circuits, a DTMF commandable responder, such as the Ameritec Model AM3-4, may be placed permanently at the distant modem where it remains transparent until commanded by DTMF signals sent from the AM-48 at the central site. In addition to performing loopback, the responder can send various tones, allowing for far-to-near tests as well as loopback tests.

EXAMPLE: 4-wire far-to-near and loopback tests for level and frequency with an Ameritec AM3-4A or AM3-4B Responder:

1. Connect an AM-48 to the near end of a 4-wire facility and an Ameritec Model AM3-4A or AM3-4B Responder at the far end. A typical configuration is illustrated in Figure 6-5.
2. Use the AM-48 keypad to send the appropriate DTMF command sequence to command the responder into milliwatt mode (responder will generate 1004 Hz, 0 dBm signal). Measure the received signal and note the level and frequency.

3. Use the AM-48 keypad to send a DTMF sequence to command the responder into loopback.
4. Use the AM-48 to send a 1004 Hz tone @ 0 dBm. Measure the loopback received level and frequency.
5. Use the AM-48 keypad to send a DTMF command sequence to restore the responder to normal.

On a 2-wire network, dial access responders are very useful in measuring far-to-near characteristics. An Ameritec AM3-2C Responder (automatic milliwatt) or AM3-2A Responder can be dialed up over the network path under test using the AM-48 keypad. It can then be commanded with touch tone from the AM-48 to make level measurements or send tones. The AM3-2C can perform far-to-near level and frequency, idle channel noise, and noise with tone. In addition to the AM3-2C functions, the AM3-2A can also perform far-to-near gain slope and near-to-far level. A typical configuration is illustrated in Figure 6-6.

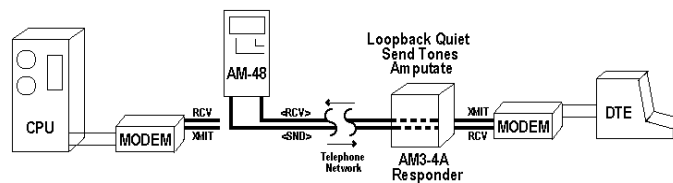

Figure 6-5. 4-Wire Testing with Responder

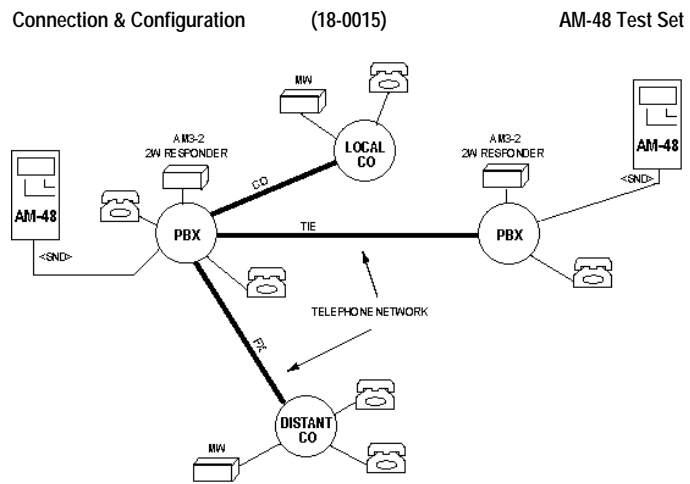

Figure 6-6. 2-Wire Network Testing with Responders

## 7. OPERATING INSTRUCTIONS

**Note:** Set up the AM-48 per Section 6 before performing operations in this section.

### 7.1 Introduction

The AM-48 operating instructions in this section are divided into five (5) major subjects and associated paragraphs as listed below:

- 7.2 General Instructions and Notes
  - 7.3 General Operating Notes
  - 7.4 Figure Format
  - 7.5 General Switch Setup
  - 7.6 Multiple Use of Keys
  - 7.7 Memory
  - 7.8 General Procedure to Set New Parameter Values
- 7.9 Send (Generator) Modes and Parameter Settings
  - 7.10 Type of Send Signals
  - 7.11 Send Quiet
  - 7.12 Set Parameters from Quiet Display
  - 7.13 Send Momentary Variable Tones
  - 7.14 Send 1004 Hz
  - 7.15 Send Continuous Variable Tone
  - 7.16 Send 3-Tone Slope
  - 7.17 Send Variable Sweep
  - 7.18 Send PAR Waveform
  - 7.19 Send Momentary 2713 Hz Tone
- 7.20 General Measure Mode Notes
  - 7.21 Accuracy of Measurements
  - 7.22 Absolute and Relative Measurements
  - 7.23 Special Measurement Requirements
  - 7.24 Timed Tests

## 7.25 Measure Modes and Parameter Settings

7.26 Measure Level and Frequency

7.27 Measure Noise

7.28 Measure PAR

7.29 Measure Impulse Noise

7.30 Measure Notched Noise

7.31 Measure S.N Ratio

7.32 Measure Phase Jitter

7.33 Measure Amplitude Jitter

7.34 Measure Transients (Impulse Noise, Notched Noise,  
Phase Hits, Gain Hits, and Dropouts)

## 7.35 Miscellaneous Operations

7.36 Store and Recall

7.37 Dialing

7.38 Talking

7.39 Printing

7.40 Auto Study Result Save

7.41 Impedance Adapter Measurement Corrections

7.42 Auto Calibrate

It is assumed in this section that the user is familiar with basic AM-48 operation, having followed the self-test instructions of Section 5. Instead of step-by-step procedures with full details, the instructions refer to the figures, which summarize the information needed to perform a test.

Read the general notes in ¶7.2 thru 7.10 and 7.20 thru 7.24 before going to specific operating instructions.

## 7.2 General Instructions and Notes

¶7.3 thru 7.8 cover general instructions and notes. These paragraphs should be read before doing a specific test or operation.

## 7.3 General Operating Notes

Keys. Do not be afraid to experiment with the keys. The AM-48 will not accept an “illegal” or meaningless keystroke. If an out-of-tolerance value is entered in a user-programmable variable field, the display will default to an acceptable value.

Displays.

1. The units of measurement appear at the top of the display, above the value. Time and count units are not shown, but are given in the table associated with the corresponding display.
2. Display decimal points will flash when batteries are low.
3. Displays of “OVER” or “UNDR” indicate the signal being monitored is too high or low to be read.
4. Depending on the mode, there may be multiple displays through which one can scroll. All displays accessible from each mode are shown in the figures.
5. To quickly go to the initial display from another display in a scroll, momentarily exit and then re-enter the same mode by moving the cursor. See the example in ¶5.7.

Check List. Go through the following check list to cover important points while performing any operation:

1. Look at the cursor positions on the menus. These indicate what SEND and MEASURE mode is selected and what noise-weighting filter is selected.

2. Note the color-coding and framing of the cursor menus and use these to determine if a filter is needed (orange functions) or a holding tone is needed (within the rectangle) for the present position of the cursors. See ¶3.7 and 7.23 for explanation of menu framing.
3. Note the setting of Switch 2, the Display Select Switch. This will indicate what is being viewed on the display. <ABS> or <REL> indicate that the display is viewing the MEASURE mode; while <SEND> indicates the display is viewing the SEND mode.
4. Note the setting of Switch 7. This indicates whether the keyboard is connected to dial (<DTMF> or <MF>) or to operate the auxiliary functions (<SHIFT>).

## 7.4 Figure Format

Figures 7-1 thru 7-9 show the display(s) which can be accessed from the indicated SEND or MEASURE mode. The position of the menu cursor, the necessary switch settings, and other pertinent information is indicated in each figure. A detailed description of the arrangement of the figures is listed below.

1. The display fields are shown with three (3) types of characters. The characters are illustrated at the bottom of some figures in a table labeled “DISPLAY CHARACTER CODE”. The meanings of the characters are:
  - a) Solid: These letters and numbers are fixed and will always appear just as they are shown. They are abbreviations for the names of the parameters.



- b) Cross-hatched: These characters represent values that are variable but cannot be changed by the user from the display in which they are shown. In the SEND modes these indicate the level and frequency being sent; in the MEASURE mode, they give the measured values.
  - c) Plain: These characters represent parameter values that are variable and can be changed by the user from the display in which they are shown.
2. Next to each display is a table of information and instructions which apply to the adjacent display. The middle column of the table gives the range of acceptable values to enter for a variable parameter or the range of values that can be measured.
  3. The SEND or MEASURE cursor setting is shown darkened on the menu just as it appears at the bottom of the AM-48 display. There are always three (3) cursors in view, although only one (1) is shown in each of the figures. The positions of the other two (2) cursors will depend upon the test configuration and setup.
  4. The switch settings are indicated next to the location of the switches in the illustration of the AM-48 at the bottom of the figure. Only the necessary switch settings for the test under consideration are shown. Set the other switches as appropriate, according to the test configuration and setup.
  5. The notes on the left at the bottom of the figures relate to the displays. The notes on the right relate to the switches and keyboard.

6. At the bottom of some figures, an alternate display(s) is illustrated, e.g., “OVER” or “UNDR”, which may be displayed to call attention to an out-of-tolerance condition.

## 7.5 General Switch Setup

See ¶3.5 for a summary of the use of each switch. Refer to Figure 3-5 for switch identification number (see ¶3.2). Follow the guidelines below for proper switch setup.

1. Make connections and set Switches 10, 11, and 13 per the line interface. See ¶6.3 thru 6.5 for details.
2. Connect and turn on power with Switch 1 per Section 4.
3. Switch 2, Display Select, determines what appears on the display. Set Switch 2 to the desired position:
  - a) <ABS> to view MEASURE display (see ¶7.22 for use of <REL> position).
  - b) <SEND> to view SEND display
4. Use Switches 5 and 6 to set the display cursor to the desired SEND and MEASURE modes, and Switch 4 to select a noise-weighting filter, if required (see Table 7-5).
5. Set Switch 7 to <SHIFT> to enable auxiliary keyboard functions to:
  - a) Scroll through multiple displays
  - b) Use keyboard to change a parameter value
  - c) Send momentary user-programmed tone from keyboard in QUIET mode
  - d) Do Store/Recall
  - e) Run a transient test
  - f) Do auto calibrate

Leave Switch 7 in <SHIFT> except when dialing.

6. Use Switches 3, 14, and 15 to connect a speaker or earphone to the desired monitoring point and adjust volume. As a rule, leave Switch 3 <OFF>.
7. Leave Switch 8 in <NOR> unless it is desired to avoid transmission of tones in the signaling frequency band (in which case, set to <SF SKIP>).
8. Use Switch 9 as required to Store and Recall setups or output information to the Printer port. See ¶7.36 and 7.39.
9. Leave Switch 12 in <ON HK> except to go off-hook on 2-wire dial access lines. <TONE> and <PULSE> are off-hook positions and connect a 200 Ω DC short across T and R.

Display Damping Switch. Set Switch 3 to <OFF> for a normal display update of four (4) times per second, or to <DAMP> to slow the display update to two (2) times per second.

Switch 3 also affects the monitor point of the speaker. Refer to the upper part of Figure 9-1 with the descriptions below:

1. With Switch 14 set to <MON RCV> and Switch 3 set to <OFF>, the speaker monitors the signal on the <RCV> jack (T1, R1) for 4-wire operation.
2. With Switch 14 set to <MON RCV> and Switch 3 set to <DAMP>, the speaker monitors the received signal (from T1, R1 in 4-wire operation, or T, R in 2-wire operation) at a point following the noise weighting filter, notch filter (if in use), and auto-ranging amplifiers. This is particularly useful for audibly monitoring the residual noise in notched noise and S/N ratio measurements.

## 7.6 Multiple Use of Keys

Multi-Function Keyboard. See Table 7-1 for different uses of the keyboard, per the setup (switch numbers per Figure 3-5).

Table 7-1. Setup Requirements for Different Keyboard Applications

<u>KEYBOARD USE</u>	<u>SWITCH 7 POSITION</u>	<u>SWITCH 12 POSITION</u>	
		2-WIRE OFF-HOOK (loop current)	2-WIRE ON-HOOK OR 4-WIRE
Dial DTMF	<DTMF>	<TONE>	<ON HK>
Dial MF	<MF>	<TONE>	<ON HK>
Dial PULSE	<DTMF> or <MF>	<PULSE>	-----
<u>DISPLAY REQUIREMENTS</u>			
Send Momentary Variable Tone	<SHIFT>	From QUIET SEND Display	
Set Parameter Values	<SHIFT>	Displays in Figures 7-1 thru 7-8 with plain ( <u>not</u> cross-hatched) characters	

Keys with Two (2) Auxiliary Functions. The (\*) and (#) key each have two (2) auxiliary functions. The [START]/[ ], on the (\*) key, and [STOP]/[ ], on the (#) key, are enabled per the setup.

The [START] and [STOP] functions only operate from certain displays in a timed test; see ¶7.24.3.

See ¶7.8.2 and .3 for explanation of the use of the [ ] and [ ] functions. When the [ ] or [ ] key is pressed continuously, the “auto-repeat” feature is enabled and repeatedly steps a parameter value at 10 times the normal step. Table 7-2 lists the momentary and continuous press steps.

Table 7-2. Steps for [ ] and [ ] Keys

PARAMETER	MOMENTARY PRESS STEP	CONTINUOUS PRESS STEP
Frequency	10 Hz	100 Hz
Level	0.1 dB	1.0 dB
Time	0.1 minute	1.0 minute

Note that in changing a level, the [ ] key steps mathematically more positive and the [ ] key steps mathematically more negative. For example, if a negative level is stepped down with the [ ] key, the value of the number itself will become larger.

## 7.7 Memory

Parameter Values Stored in Memory. Some user-programmable parameter values are stored in volatile memory and others are stored in non-volatile memory. Table 7-3 lists the variable parameters and indicates in which memory they are stored. General information about the two (2) types of memory is given below:

1. Volatile Memory. User-set values stored here will be stored as long as the AM-48 power is on or until changed by the user. When power is turned off or times out (after turning on with the momentary power switch), the user-set volatile memory values will be lost and revert to the default values.
2. Non-Volatile Memory. Values stored here will stay stored even if AM-48 power is turned off. They will remain until changed to another value by the user. Also stored in non-volatile memory are the results and the parameter settings of the last timed impulse noise or transient test. Note that the timed test information is not stored in non-volatile memory unless the test is actually run.

In order to allow the transfer of timed test information into non-volatile memory, the AM-48 power will not time-out during a timed study. The time-out timer restarts at the end of a timed study.

Level Display. There is only one level setting and it is stored in volatile memory. For convenience, the level display that shows this value can be accessed from any SEND display. The level display is always the second display in the scroll. To access the level display:

1. Set Switch 2 to <SEND>.
2. Set Switch 7 to <SHIFT>.
3. Rock Switch 6 to select any SEND mode.
4. Press [ETR/NEXT]
5. Level display will appear.

Remember that when the level value is changed, it changes the level for all SEND signals, except for dialed tones (see ¶7.12.3 for instructions to set touch tone level). When power is turned off, the send level always defaults to 00.0 dBm. The level for dialed tones, however, is stored in non-volatile memory.

Store/Recall. Up to 10 test setups, including parameter values, can be stored in non-volatile memory. A stored test setup can be recalled, avoiding the need to set cursors and re-enter parameter values for a routine test. See ¶7.36 for instructions.

Table 7-3. User-Programmable Parameter Values Stored in Memory

<b><u>VOLATILE MEMORY</u></b>	
<b>PARAMETER</b>	<b>DEFAULT LEVEL</b>
Level	00.0 dBm
Variable Frequency	1004 Hz
Variable Sweep Start Frequency	204 Hz
Stop Frequency	19,904 Hz
Step	100 Hz
Rate	1.0 sec
Jitter Bandpass Range	20 Hz – 300 Hz
<b><u>NON-VOLATILE MEMORY</u></b>	
<b>PARAMETER</b>	<b>FACTORY SETTINGS</b>
Dial Level (DTMF and MF)	-10.0 dBm
Blanking Interval	125 ms
Time Off with Momentary Power	16 minutes
10 Momentary Frequencies (with Volatile Memory Level)	Not Applicable
10 Test Setups (Stored on Number Keys using <RCL/STO>)	Not Applicable
Timed Test Parameters Duration of Timed Test Impulse Noise Delta Impulse Noise Threshold Phase Hit Threshold Gain Hit Threshold	Not Applicable
Timed Test Results Time Elapsed Low Impulse Count Middle Impulse Count High Impulse Count Noise Phase Hit Count Gain Hit Count Dropouts Phase Locked Loop Frequency	Not Applicable

## 7.8 General Procedure to Set New Parameter Values

**Note:** Set Switch 7 to <SHIFT> to enable the keys to perform the auxiliary functions.  
See ¶7.36 for instructions to store new parameter values for future use.

Items 2, 3, 4, 5, 7, and 8 shown in Figure 3-6 are the auxiliary keyboard functions that are used together with the number keys to set new parameter values. ¶3.6 explains how these keys are used.

See ¶5.7, Steps N thru HH, for an example of setting new parameter values. To summarize, there are three (3) procedures used to set new parameter values (confirm Switch 7 in <SHIFT>).

1. Scroll Through the Displays. To view the displays without making any changes in parameter values:
  - (a) Press [ETR/NEXT] to go to the next display.
  - (b) Press [ETR/PREV] to go to the previous display.
2. Set a New Parameter Value Using the Number Keys.
  - (a) Press any number key or the [±] key to clear the display of the old parameter value and start writing a new value on the display.

**Note:** Now the [ ] and [ ] keys will not work.

Finish writing the new value with the number keys.

- b) If a mistake is made in Step a), press [CANCEL] to clear the display and view the old value.
- c) After using the number keys to write a new value in Step a), press either [ETR/NEXT] or [ETR/PREV] to enter the new value into memory, replacing the old value.



**Note:** Now [CANCEL] will not work.

- d) Use Step1 to go to another display.
3. Set a New Parameter Value Using the [ ] and [ ] Keys.
- a) Press [ ] and/or [ ] to step the displayed parameter value up or down to a new value. To step in increments 10 times the normal increment, hold the key down continuously. See Table 7-2 for step values. The new value displayed is entered directly into memory, replacing the old value.
  - b) The [CANCEL] key will not work here because the new value directly replaces the old value in memory.
  - c) [±] can not be used to change the sign because it will clear the display (see Step 2a).
  - d) Use Step1 to go to another display.

## 7.9 Send (Generator) Modes and Parameter Settings

Paragraphs 7.10 thru 7.19 discuss the SEND modes.

**Note:** For all SEND modes, set Switch 8 to <SF SKIP> to prevent sending tones in the signaling band of 2450 Hz to 2750 Hz (2130 Hz to 2430 Hz for AM-48E). Set Switch 8 to <NOR> to allow all frequencies to be sent.

## 7.10 Types of Send Signals

The AM-48 Send signals can be classified according to their duration. The three (3) types of Send signals are:

1. Momentary
2. Continuous
3. Stepped (Slope and Sweep)

To send a variable momentary tone, set the SEND cursor to QUIET and set the level and frequency per instructions in ¶7.12.1 and 7.12.2. Send the frequency from the QUIET SEND display by pressing the number to which the tone is assigned. Momentarily press Switch 8 to <X TONE> to send momentary 2713 Hz tone (¶7.19).

To send a variable continuous tone, set the SEND cursor to VAR and set the desired level and frequency per ¶7.15.

To send continuous 1004 Hz, set the SEND cursor to 1004 (¶7.14). To send continuous PAR, set the SEND cursor to PAR (¶7.18).

To send a pre-programmed set of slope frequencies, set the SEND cursor to 3TONE (SLOPE for the AM-48E) (see ¶7.16).

To send variable sweep set the SEND cursor to SWEEP (¶7.17).

## 7.11 Send Quiet

1. See Figure 7-1. Set switches per the SWITCH SETUP illustration and the SEND cursor per the menu illustration.
2. A Quiet termination display will appear, “\_ \_ \_ \_ \_”, confirming that the AM-48 is quiet terminated.

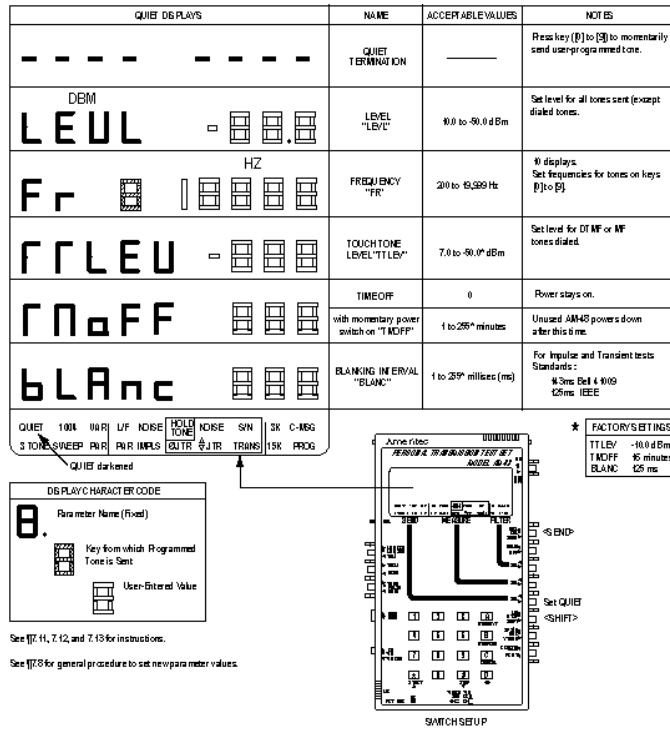

Figure 7-1. Parameter Settings from QUIET SEND Display

## 7.12 Set Parameters from Quiet Display

There are a total of 15 displays in the QUIET SEND mode. The third display in Figure 7-1, "FR 8 18888", represents 10 different displays, from "FR 0 18888" to "FR 9 18888".

See Figure 7-1 for all parameter settings in this paragraph. Set switches per the SWITCH SETUP illustration, and set the SEND cursor per the menu illustration.

1. Set Level (see Figure 7-1 and ¶7.8).
  - a) Go to “LEVL” display.
  - b) Set desired level value (default value is 00.0 dBm).
  - c) New level value is stored in volatile memory.
2. Set Up to 10 Frequencies, sent with number keys from QUIET display (see Figure 7-1 and ¶7.8).
  - a) Go to desired “FR” display - - one (1) of 10.
  - b) The number after “FR” identifies the number key onto which the frequency is programmed.
  - c) Set desired frequency value.
  - d) This value is stored in non-volatile memory.
  - e) Repeat Steps a) and c) for other frequencies as desired.
3. Set Touch Tone Level (see Figure 7-1 and ¶7.8).
  - a) Go to “TTLEV” display.
  - b) Set desired level value for DTMF and MF dialing.
  - c) Recommended level (factory setting) is -10.0 dBm.
  - d) This value is stored in non-volatile memory.
4. Set Time Off: operates when power is turned on with the momentary power switch (see Figure 7-1 and ¶7.8).
  - a) Go to “TMOFF” display.
  - b) Set desired time value.
  - c) This value is stored in non-volatile memory (factory setting is 16 minutes).
  - d) This time is when the AM-48 will turn off after the last key or switch activity, if the unit has been turned on with the momentary power switch.

- e) Note that the AM-48 will not turn itself off if a time of “0” is set. A time of “0” is not a desirable setting when using batteries.
5. Set Blanking Interval (see Figure 7-1 and ¶7.8).
- a) Go to “BLANC” display.
  - b) Set desired blanking interval value.
  - c) This value is stored in non-volatile memory (factory setting is 125 ms).
  - d) The meaning of the blanking interval for timed tests is explained in ¶8.9.
  - e) Note the Bell and IEEE standard settings listed in Figure 7-1.

### 7.13 Send Momentary Variable Tones

1. With the switches and cursor set per Figure 7-1, program desired frequencies on the number keys per ¶7.12.2.
2. The level of the tone sent is the value in the “LEVL” display, stored in volatile memory (factory setting is 125 ms).
3. Go to the QUIET termination display, “\_\_\_\_\_”.

**Note:** First select “SEND 1004” and then step backwards to select QUIET termination.

4. Press the appropriate number key; [0], [1], [2], . . . [9], to send the desired frequency.
5. The tone will be sent for as long as the key is held down.

### 7.14 Send 1004 Hz

1. See Figure 7-2. Set switches per the SWITCH SETUP illustration, and set the SEND cursor per the lower menu illustration.
2. Go to the "LEVL" display and set the desired level value.

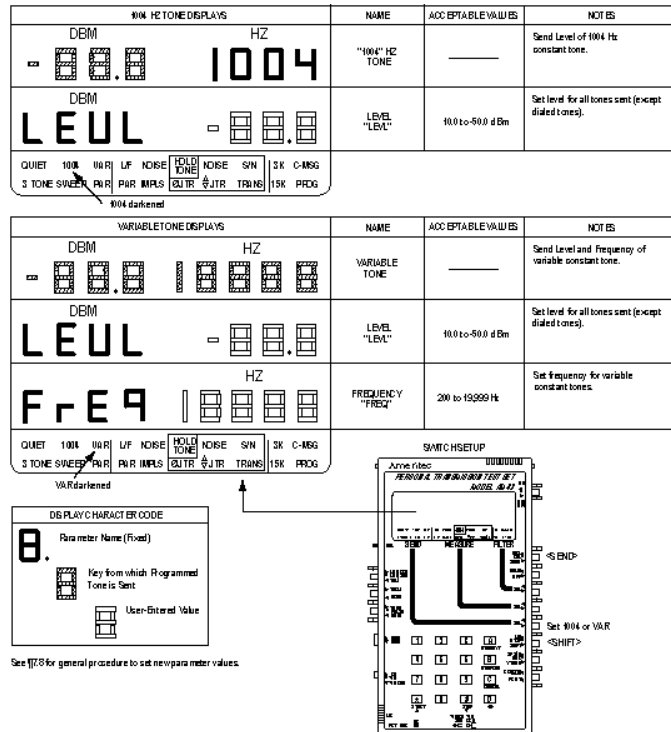

Figure 7-2. Parameter Settings from 1004 Hz and VAR Tone Send Displays

### 7.15 Send Continuous Variable Tone

1. See Figure 7-2. Set switches per the SWITCH SETUP illustration, and set the SEND cursor per the lower menu illustration.
2. Go to the “LEVL” display and set the desired level value.
3. Go to the “FREQ” display and set the desired frequency value.

### 7.16 Send Set of Slope Tones

1. See Figure 7-3. Set switches per the SWITCH SETUP illustration, and set the SEND cursor per the upper menu illustration.
2. Go to the “LEVL” display and set the desired level value.
3. Go to the initial display and note that the frequencies 404 Hz, 1004 Hz, and 2804 Hz (404 Hz, 1004 Hz, 2004 Hz, and 3004 Hz for AM-48E) are sent in a cycle @ 5 seconds.

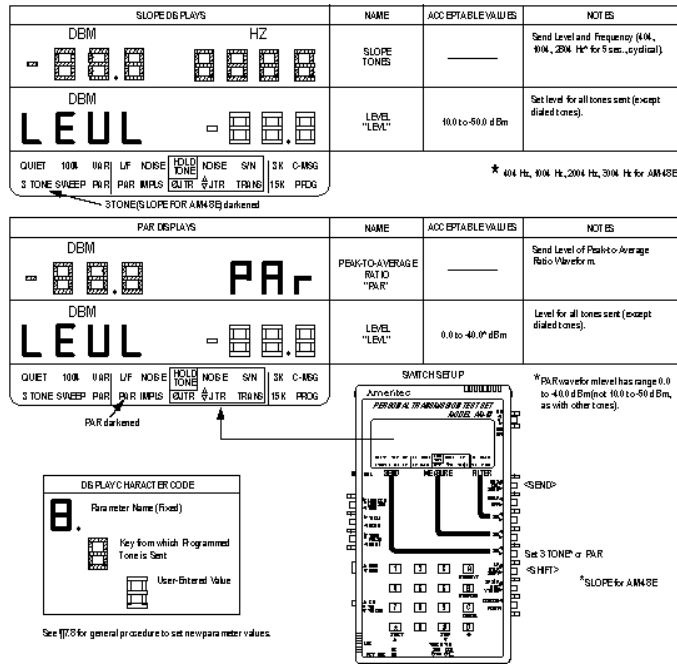

Figure 7-3. Parameter Settings from 3-TONE Slope and PAR SEND Displays

### 7.17 Send Variable Sweep

See ¶5.7 for an example of setting the parameter values for this SEND mode. Figure 5-7 shows the displays with the default parameter settings. Figure 7-4 shows the general displays.

1. See Figure 7-4. Set switches per the SWITCH SETUP illustration, and set the SEND cursor per the menu illustration.
2. See ¶7.8. Set the parameter values for the desired sweep per the acceptable values and notes in Figure 7-4.
3. The new parameter values are stored in volatile memory.



4. To start the sweep at the Start frequency, momentarily move the SEND cursor out of SWEEP mode and then re-enter SWEEP mode. As soon as SWEEP mode is entered, the sweep will begin at the Start frequency.
5. Press <RCL/STO> with Switch 9 to store this setup in non-volatile memory for future use. See ¶7.36.

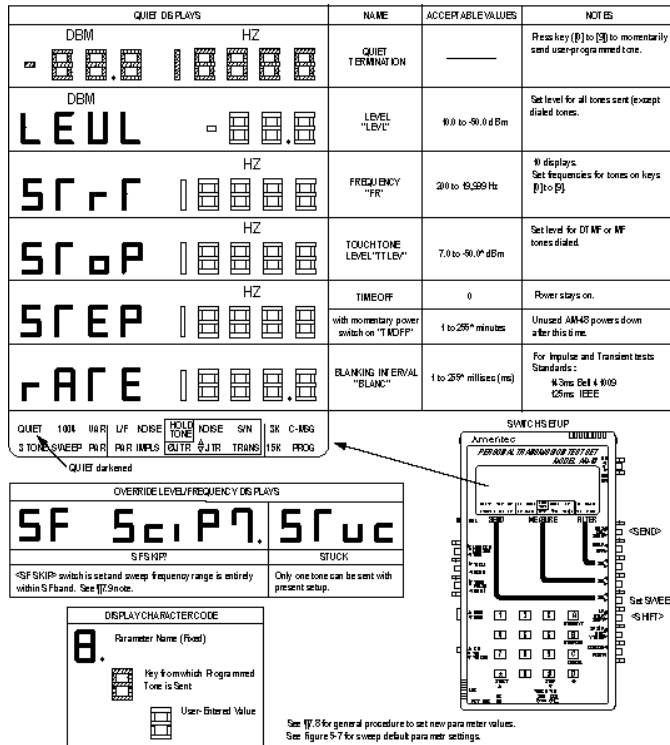

Figure 7-4. Parameter Settings from SWEEP SEND Display

## 7.18 Send PAR Waveform

1. See Figure 7-3. Set switches per the SWITCH SETUP illustration, and set the SEND cursor per the lower menu illustration.
2. Go to the “LEVL” display and set the desired level value.
3. PAR level is limited to the range 00.0 dBm to –40.0 dBm.
4. If the level were above 00.0 dBm or below –40.0 dBm, the PAR level would default to 00.0 dBm or –40.0 dBm, respectively, while sending PAR. For this case, if no new level value were set while in the PAR mode, the level value would return to its previous value after exiting PAR.

## 7.19 Send Momentary 2713 Hz Tone

Press <X TONE> with Switch 8 to momentarily send a 2713 Hz tone, overriding the internal signal generator. This is used to activate loopback devices. See “Loopback Testing” in ¶6.6.

## 7.20 ¶7.21 thru 7.24 cover general instructions and Notes for the MEASURE Modes.

## 7.21 Accuracy of Measurements

Observe instructions listed here to ensure accurate readings with the AM-48.

1. Be sure Switch 12 is in <ON HK> except when an off-hook condition is desired for 2-wire access lines. Switch 12 in <TONE> or <PULSE> will cause erroneous readings for measurements on 4-wire circuits.

2. Be sure that Switch 11 is set to match the line impedance. Generally, <600 > matches 4-wire and <900 > matches 2-wire. A wrong Switch 11 setting results in about 1.8 dB error in level and noise measurements.
3. Use batteries when making low-level noise measurements.
4. For 2-wire measurements (Switch 2 in <ABS> or <REL>), set the SEND Cursor to QUIET mode; if not, the AM-48 will be measuring its own generator output in addition to the signal received from the far end of the line.
5. When using the Impedance Adapter (§6.5 and 9.3), correct the measurements per instructions in ¶7.41.

## 7.22 Absolute and Relative Measurements

See ¶8.2 for a discussion of units of measurement, including Absolute and Relative measurements.

Either an Absolute or Relative measurement can be made with any level or noise measurement. The choice is made by setting the Display Switch, Switch 2, to either <ABS> or <REL>. The use of <ABS> and <REL> is outlined below:

1. Normally, the absolute (<ABS>) setting is used for noise and level measurements.
2. The <REL> position is used to establish a new zero reference level. This is useful in tests such as frequency response, where levels at various frequencies are to be compared with the level at a reference frequency.

To use <REL>:

1. Start with Switch 2 in <ABS>.

2. When the desired reference point is established, set Switch 2 to <REL>.
3. When <REL> is first selected, the display will read “00.0 dB REL”, meaning that the level or noise reading is now referenced to the reading that was on the display when <REL> was pressed.
4. Subsequent readings are now referenced to this new zero reference.
5. To summarize, “REL” means “relative to the last reading before <REL> was pressed”.

EXAMPLE: Changing from <ABS> to <REL> with a level measurement.

1. With the MEASURE cursor in L/F and Switch 2 set to <ABS>, a level of “-17.7 dBm” is displayed.
2. Set Switch 2 to <REL>. The reading is now “00.0 dB REL”.
3. With Switch 2 still in <REL>, the reading changes to “-02.3 dB REL”. This means that the level is -2.3 dB relative to the reading just before <REL> was set.
4. The absolute reading would be  $-17.7 + -2.3 = -20.0$  dBm.

## 7.23 Special Measurement Requirements

Certain measurements require one or more of the following conditions in order to be valid:

1. 1004 Hz nominal Holding Tone.
2. One (1) of the following noise-weighting filters:
  - a) C-Message, C-MSG (Psophometric, PSHO for AM-48E)
  - b) 3 kHz, 3K
  - c) 15 kHz, 15K
  - d) Program PROG (Sound-weighted, SWTD for AM-48E)

### 3. PAR waveform

The AM-48 can send 1004 Hz and PAR waveform (¶7.14 and 7.18).

To select a noise-weighting filter, rock Switch 4, Filter Select, to set the FILTER menu cursor to the desired filter.

Table 7-5 defines which measurements require special conditions.

The AM-48 menus are color-coded and framed, as explained below, to indicate which measurements require a noise-weighting filter and which require a Holding Tone. Note that some measurements require both.

Color Coding. The filters on the FILTER menu are written in orange.

The tests which require one of these noise-weighting filters are also written in orange on the MEASURE mode menu.

Menu Framing. Refer to Figure 3-8. There is a pink rectangle within the MEASURE menu. In the upper left-hand corner of this rectangle is a box enclosing HOLD TONE. The HOLD TONE indicator will have a dark background (like a cursor) when a valid 1004 Hz Holding Tone is present at the receive port. Each MEASURE test within the rectangle requires a valid 1004 Hz Holding Tone at the receive port for the measurement to be accurate.

Holding Tone Ranges. See Table 7-4 for holding tone range specifications, which depend upon the type of measurement.

Table 7-4. Acceptable Holding Tone Ranges

ACCEPTABLE RANGE	TYPE OF MEASUREMENT
990 Hz to 1030 Hz	Phase Jitter and Amplitude Jitter
995 Hz to 1025 Hz	All other holding tone tests

Table 7-5. Special Measurement Requirements

MEASUREMENT	REQUIREMENT(S)		
	HOLDING TONE	NOISE-WEIGHTING FILTER	PAR WAVEFORM
Noise		X	
PAR			X
Impulse Noise		X	
Notched Noise	X	X	
S/N Ratio	X	X	
Phase Jitter	X		
Amplitude Jitter	X		
Transients			
Notched Noise	X	X	
Impulse Noise	X	X	
Phase Hits	X		
Gain Hits	X		
Dropouts	X		

## 7.24 Timed Tests

A timed study is made with the Impulse Noise and Transient tests.

See ¶7.29 and 7.34. In general, for AM-48 timed tests:

1. The time over which the study is to be made and the constraints (thresholds and blanking interval) are programmed before the test.
2. The [START] key is used to start a test, and the [STOP] key to stop a test in progress before the programmed time-out. Pressing [START] disables the power-off timer.

3. A test may be started or stopped from any display showing a measurement, indicated in Figures 7-6 and 7-9 by a cross-hatched character variable field. These displays are also labeled on the left side with “S/S”, meaning “start/stop”. A test may not be started from a display used to set a parameter, because the [ ] and [ ] functions are performed on the same keys that would be used for the [START] and [STOP].
4. The cursor (IMPLS or TRANS) will flash while the test is running. The cursor will flash until [STOP] is pressed, or the duration time, indicated in the initial “DUR” display, is reached.
5. The “TIME” display, indicating time elapsed into the run, will reset to 0.0 minutes each time [START] is pressed.
6. If a printer is connected, an automatic printout will be delivered every 15 minutes during the test, and also at the end of the test.
7. After a timed test has been run, the setup parameters and the measurements are stored in non-volatile memory for future reference. At the end of the run, the power-off timer starts running with maximum time.

## MEASURE MODES AND PARAMETER SETTINGS

**7.25 ¶7.26 thru 7.34 cover the MEASURE modes.**

### 7.26 Measure Level and Frequency

1. See ¶8.3 for information on this measurement.
2. 1004 Hz @ 0 dBm is normally sent from the far end.
3. See Figure 7-5. Set switches per the SWITCH SETUP illustration, and set the MEASURE cursor per the top menu illustration (L/F DISPLAY).

4. Read the level and frequency on the display.

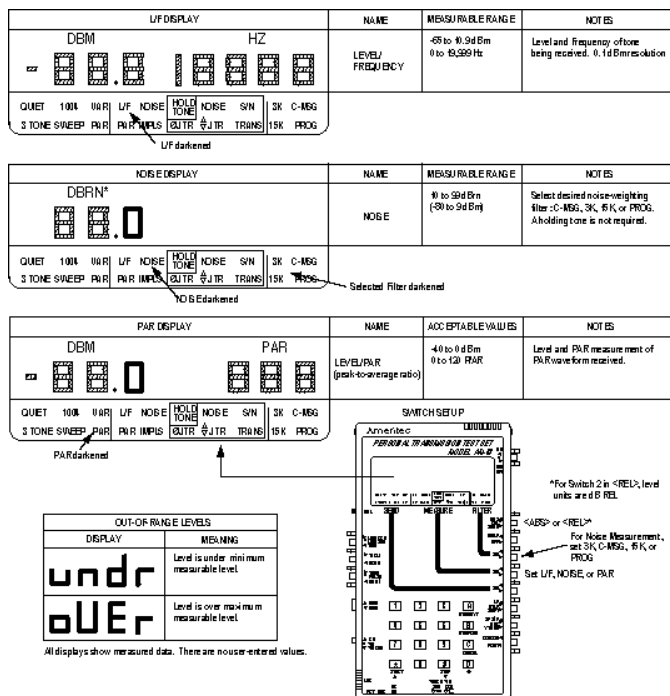

Figure 7-5. L/F, NOISE, and PAR MEASURE Displays

### 7.27 Measure Noise

1. See ¶8.4 for information on this measurement.
2. The distant end is normally Quiet Terminated.
3. See Figure 7-5. Set switches per the SWITCH SETUP illustration, and set the MEASURE cursor per the middle menu illustration (NOISE DISPLAY).
4. A noise-weighting filter is used for this measurement. Set the FILTER cursor for the desired filter as indicated in Figure 7-5.



5. Read the noise on the display. Note that the reading will always be a whole number.

## 7.28 Measure PAR

1. See ¶8.7 for information on this measurement.
2. A PAR waveform must be sent from the far end for this measurement to be valid.
3. See Figure 7-5. Set switches per the SWITCH SETUP illustration, and set the MEASURE cursor per the bottom menu illustration (PAR DISPLAY).
4. Read the level and PAR value on the display. Note that the readings will always be a whole numbers.

## 7.29 Measure Impulse Noise

### General Information

1. This is a timed test. See ¶7.24.
2. Three (3) noise thresholds are established: low, middle, and high. There is an equal interval between each threshold called the delta.
3. The time over which the run is to be made is set, called the duration.
4. The run is started, and a running count is kept of the number of noise pulses that exceed each threshold.
5. The run will automatically stop when the duration time is reached, or the test can be manually stopped at any previous time.
6. The "TIME" display resets to zero at the beginning of a run, and keeps a running count of the time elapsed during the run.

7. If a run is left to continue until the duration time that was set is reached, both the “DUR” and “TIME” displays will read the same at the end of the run.
8. A blanking interval is set, during which time the noise pulse counter does not count.
9. See ¶8.9 for more details about (idle channel) impulse noise measurements.

Procedure (see ¶7.8)

1. Set the blanking interval per ¶7.12.5.
2. See Figure 7-6. Set switches per the SWITCH SETUP illustration, and set the MEASURE cursor per the menu illustration.
3. Go to the “DUR” display. Set the desired duration for the test.
4. Go to the “ITHLD” display and set the Low impulse noise threshold. The minimum setting of the Low impulse noise threshold is 30 dBrn. The maximum setting is such that the High impulse noise threshold will not exceed 105 dBrn for 600 impedance (or 104 dBrn for 900 ). The High impulse noise threshold = Low threshold + 2 Delta (see Figure 8-2). For example, with a Delta = 2 dB and 600 impedance, the maximum Low threshold would be 101 dBrn [101 dBrn + 2 (2 dB) = 101 + 4 = 105 dBrn, maximum High threshold].
5. Go to the “IDELTA” display and set the desired Delta (equal interval between the three (3) thresholds).
6. A noise-weighting filter is used for this measurement. Set the FILTER cursor for the desired filter as indicated in Figure 7-6.
7. To start the run, go to any display marked “S/S” (in the left margin) and press [START]. The IMPLS cursor will start to flash.

8. At any time, go to the “NOISE” display and read the real time noise (always a whole number).
9. To stop the run before the duration time has elapsed, press [STOP]. The IMPLS cursor will stop flashing.
10. When a run is stopped before the duration (“DUR”) time is up, read the “TIME” display for the actual time of the run.
11. After the run, go to the respective display to read the low, middle, and high threshold noise counts.
12. After the run, the parameter settings and the readings are stored in non-volatile memory.



3. Display indicates frequency of received holding tone, which must be from 995 Hz to 1025 Hz to be valid. Be sure HOLD TONE cursor is darkened, indicating a valid holding tone is being received.
4. A noise-weighting filter is used for this measurement. Set the FILTER cursor for the desired filter as indicated in Figure 7-7.
5. Read the notched noise on the display. Note that the reading will always be a whole number.
6. Set Switch 3 to <DAMP> and Switch 14 to <MON RCV> to audibly monitor the residual noise (see ¶7.5 under Display Damping Switch).

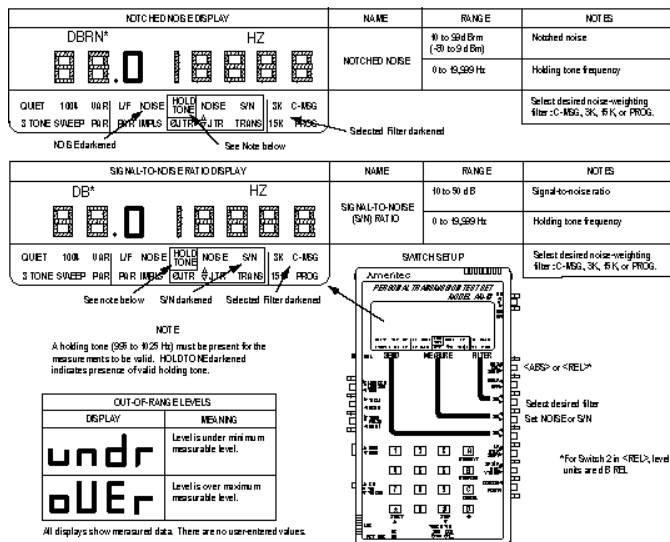

Figure 7-7. Notched NOISE and S/N Ratio MEASURE Displays

### 7.31 Measure S/N Ratio

1. See ¶8.6 for explanation of S/N Ratio measurement.
2. See Figure 7-7. Set switches per the SWITCH SETUP illustration, and set the MEASURE cursor per the bottom menu illustration (SIGNAL-TO-NOISE RATIO DISPLAY).
3. Display indicates frequency of received holding tone, which must be from 995 Hz to 1025 Hz to be valid. Be sure HOLD TONE cursor is darkened, indicating a valid holding tone is being received.
4. A noise-weighting filter is used for this measurement. Set the FILTER cursor for the desired filter as indicated in Figure 7-7.
5. Read the signal-to-noise ratio on the display. Note that the reading will always be a whole number.
6. Set Switch 3 to <DAMP> and Switch 14 to <MON RCV> to audibly monitor the residual noise (see ¶7.5 under Display Damping Switch).

### 7.32 Measure Phase Jitter

1. See ¶8.10 for explanation of Phase Jitter measurement.
2. See Figure 7-8. Set switches per the SWITCH SETUP illustration, and set the MEASURE cursor per the top menu illustration (PHASE JITTER DISPLAYS).
3. Go to “PLL” display. This indicates the phase-locked loop generator frequency, which must be from 990 Hz to 1030 Hz for a valid measurement. Be sure HOLD TONE cursor is darkened, indicating a valid holding tone is being received.
4. Go to “RANGE” display. Press [4] or [2] for desired bandwidth (4 Hz to 300 Hz or 20 Hz to 300 Hz).

5. Go to “JTR” display and read the peak-to-peak phase jitter.

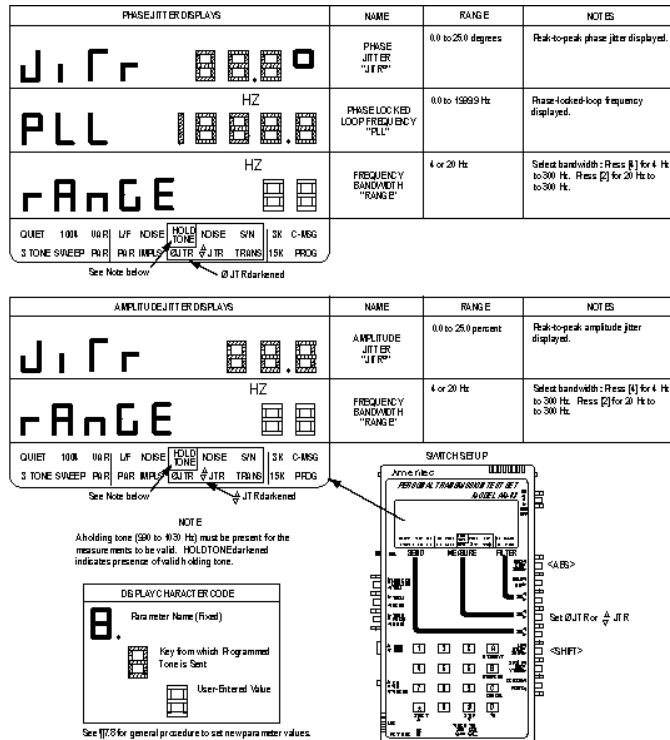

Figure 7-8. Phase JTR and Amplitude JTR MEASURE Displays

### 7.33 Measure Amplitude Jitter

1. See ¶8.11 for explanation of Amplitude Jitter measurement.
2. See Figure 7-8. Set switches per the SWITCH SETUP illustration, and set the MEASURE cursor per the bottom menu illustration (AMPLITUDE JITTER DISPLAYS).
3. Be sure HOLD TONE cursor is darkened, indicating a valid holding tone is being received.

4. Go to “RANGE” display. Press [4] or [2] for desired bandwidth (4 Hz to 300 Hz or 20 Hz to 300 Hz).
5. Go to “JITR” display and read the peak-to-peak amplitude jitter.

### 7.34 Measure Transients

These are timed tests, any or all of which can be performed at the same time. See ¶7.24 for general information.

There are a total of 14 displays in the TRANS MEASURE mode, shown in the two (2) pages of Figure 7-9.

See Figure 7-9 for all parameter settings and operations described in this paragraph. Set switches per the SWITCH SETUP illustration, and set the MEASURE and FILTER cursors per the menu illustration.

1. Measure Notched Impulse Noise. This measurement is identical to the (idle channel) Impulse Noise measurement except that a holding tone is required. The operating instructions are thus identical, as indicated below.
  - a) Be sure HOLD TONE cursor is darkened, indicating a valid holding tone.
  - b) See Figure 7-9. Note that the first eight (8) displays in Figure 7-9 are identical to the eight (8) displays in Figure 7-6.
  - c) Follow the procedure in ¶7.29, except that the TRANS cursor will be darkened and flash during the run instead of the IMPLS cursor. Note that the “NOISE” display reads notched noise instead of idle channel noise.



2. Measure Phase Hits. See ¶8.13 for explanation of phase hit measurement.
  - a) See Figure 7-9. Be sure HOLD TONE cursor is darkened.
  - b) Go to “DUR” display and set the desired duration for the test.
  - c) Go to “PTHLD” display and set the phase hit threshold.
  - d) Go to any display labeled “S/S” and press [START]; the TRANS cursor will start to flash.
  - e) To stop the run before the duration time has elapsed, press [STOP]. The TRANS cursor will stop flashing.
  - f) When the run is stopped before the duration (“DUR”) time is up, read the “TIME” display for the actual time of the run.
  - g) After the run, go to “PHIT” display to read the number of phase hits.
  - h) After the run, the parameter settings and the readings are stored in non-volatile memory.
3. Measure Gain Hits. See ¶8.14 for explanation of gain hit measurement.
  - a) See Figure 7-9. Be sure HOLD TONE cursor is darkened.
  - b) Go to “DUR” display and set the desired duration for the test.
  - c) Go to “GTHLD” display and set the gain hit threshold.
  - d) Go to any display labeled “S/S” and press [START]; the TRANS cursor will start to flash.

- e) To stop the run before the duration time has elapsed, press [STOP]. The TRANS cursor will stop flashing.
  - f) When the run is stopped before the duration (“DUR”) time is up, read the “TIME” display for the actual time of the run.
  - g) After the run, go to “GHIT” display to read the number of gain hits.
  - h) After the run, the parameter settings and the readings are stored in non-volatile memory.
4. Measure Dropouts. See ¶8.15 for explanation of dropouts measurement.
- a) See Figure 7-9. Be sure HOLD TONE cursor is darkened.
  - b) Go to “DUR” display and set the desired duration for the test.
  - c) Go to any display labeled “S/S” and press [START]; the TRANS cursor will start to flash.
  - d) To stop the run before the duration time has elapsed, press [STOP]. The TRANS cursor will stop flashing.
  - e) When the run is stopped before the duration (“DUR”) time is up, read the “TIME” display for the actual time of the run.
  - f) After the run, go to “DROP” display to read the number of dropouts (loss of holding tone).
  - g) After the run, the parameter settings and the readings are stored in non-volatile memory.

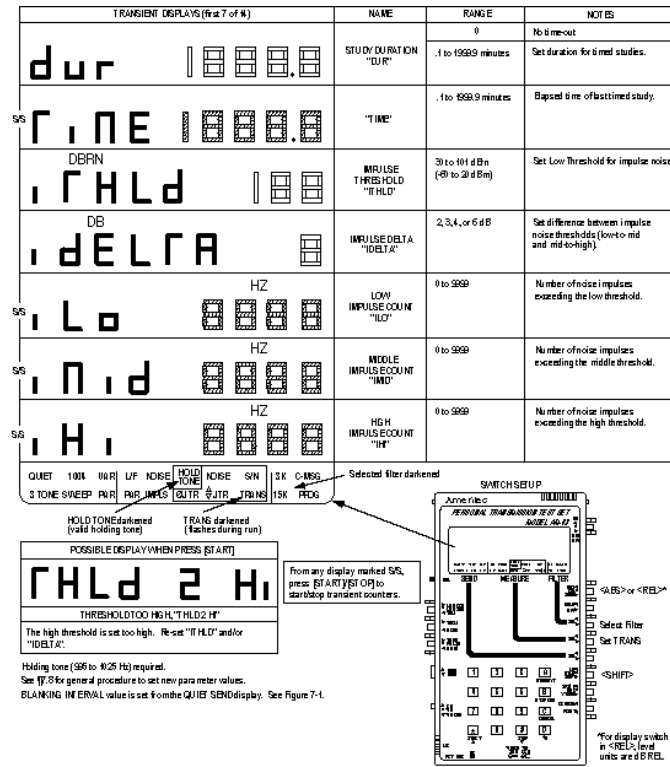

Figure 7-9. TRANS MEASURE Displays, Page 1 of 2

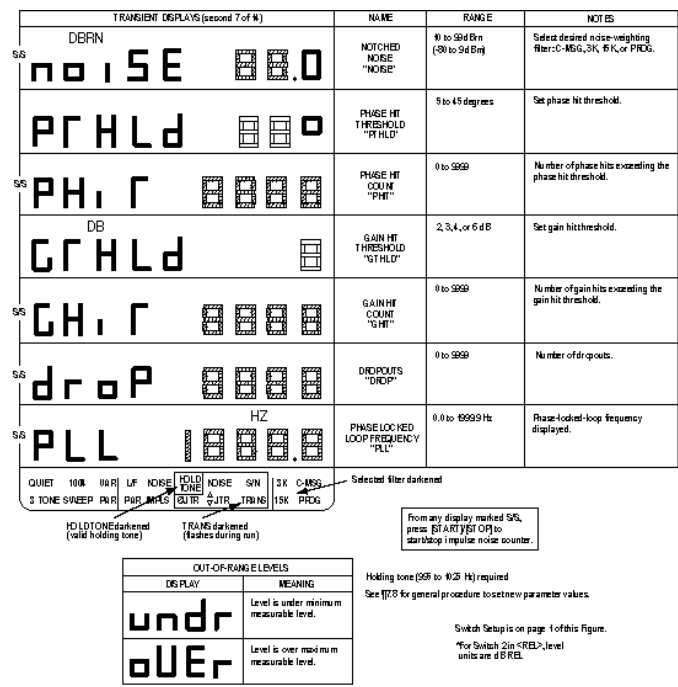

Figure 7-9. TRANS MEASURE Displays, Page 2 of 2

MISCELLANEOUS OPERATIONS

7.35 ¶7.36 thru 7.42 cover miscellaneous AM-48 operations.

7.36 Store and Recall

The Store and Recall feature is very useful to quickly set up a test that was previously set up. The parameters and cursor settings are stored in non-volatile memory after they are first programmed, and are recalled each time the test is repeated. Refer to Figure 7-10.

Recall. To recall a test setup previously stored:

1. Momentarily press Switch 9 to <RCL/STO>.
2. The prompt “RECALL?” will appear on the display.
3. Press a number key [0] thru [9] to recall a setup previously stored on that key, or press [CANCEL] to abort.

Store. To store:

1. Adjust the AM-48 to the test setup and parameter settings to be stored.
2. Press and hold Switch 9 to <RCL/STO> for about five (5) seconds. <STO> is underlined to indicate that the store function is enabled when Switch 9 is held down.
3. The “RECALL?” prompt will then change to “STORE?”.
4. Press a number key [0] thru [9] to store the setup on that key, or press [CANCEL] to abort.

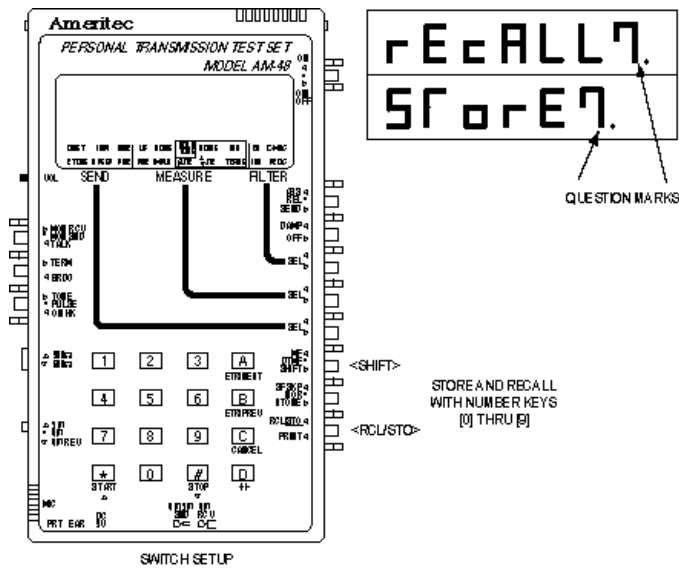

Figure 7-10. Recall and Store Operations

Parameters and cursor settings that are saved/stored by the STORE/RECALL function are listed below:

- Send Mode
- Noise-Weighting Filter Selected
- Send Variable Frequency
- Sweep Stop Frequency
- Sweep Rate
- Elapsed Time
- Impulse Delta Threshold
- Gain Hit Threshold
- Jitter Range (4 Hz or 20 Hz High Pass)
- Measure Mode
- Send Level
- Sweep Start Frequency
- Sweep Step Frequency
- Duration Time
- Impulse Threshold
- Phase Hit Threshold

### 7.37 Dialing

1. For DTMF or MF dialing, set desired send level per ¶7.12.3.
2. Set Switch 10 to <2W>, <4W>, or <4W REV> for desired 2-wire or 4-wire line connection.
3. Match line impedance per ¶6.4 or 6.5. For Dial Pulse (DP), set Switch 13 to <BRDG> while dialing, and set to <TERM> when making measurements.
4. Set Switches 7 and 12 for dialing mode per Table 7-6.
5. The line connected to the AM-48 should provide dial tone. Adjust speaker volume to a comfortable level.
6. Table 7-7 lists the MF and DTMF dual tones on each of the keys. Note that there is no MF on key [D].
7. Dial number using keypad. See Figure 5-6 for dial display when Switch 2 is in <SEND>. If timeout occurs, go back on hook by setting Switch 12 to <ON HK> for two to three seconds, then switch back to <PULSE> or <TONE> to go back off-hook. Re-enter dialed number.
8. If a person has been dialed, press Switch 14 to <TALK> and speak into the microphone. To listen to the other person, release <TALK> to <MON SND>.
9. If an Ameritec AM3-2A DTMF Commandable Responder has been called, it will automatically answer ringing and be open to DTMF commands. See Table 7-6 for DTMF dialing setup and dial appropriate DTMF commands.

Table 7-6. Setup Requirements for Dialing

DIAL MODE	SWITCH 7 POSITION	SWITCH 12 POSITION	
		2-WIRE OFF-HOOK (loop current)	2-WIRE ON-HOOK or 4-WIRE
Dial DTMF	<DTMF>	<TONE>	<ON HK>
Dial MF	<MF>	<TONE>	<ON HK>
Dial Pulse	<DTMF> or <MF>	<PULSE>	-----

Table 7-7. MF and DTMF Tone Pairs

KEY	MF TONE PAIRS (Hz)	DTMF TONE PAIRS (Hz)
[1]	700/900	1209/697
[2]	700/1100	1336/697
[3]	900/1100	1477/697
[4]	700/1300	1209/770
[5]	900/1300	1336/770
[6]	1100/1300	1477/770
[7]	700/1500	1209/852
[8]	900/1500	1336/852
[9]	1100/1500	1477/852
[*] (KP)	1100/1700	1209/941
[0]	1300/1500	1336/941
[#] (ST)	1500/1700	1477/941
[A] (ST3P)	700/1700	1633/697
[B] (STP)	900/1700	1633/770
[C] (ST2P)	1300/1700	1633/852
[D]		1633/941



## 7.38 Talking

The AM-48 can be used as a telephone “butt-set” (also see ¶3.5.14).

1. To talk, hold down Switch 14 in <TALK> position and speak into the microphone (labeled MIC). See Figure 3-1 for microphone location.
2. “VOICE” appears on the display when <TALK> is pressed and Switch 2 is in <SEND>.
3. To listen, release <TALK> switch to <MON SND>. SEND cursor will default to QUIET mode.
4. For more privacy or better listening clarity, use the earphone supplied with the AM-48.
5. See Figure 3-2 for the location of the earphone jack, <EAR>, on the bottom of the AM-48.

## 7.39 Printing

This paragraph is divided into two (2) main parts:

- A. Operation instructions for the AM-47 Hand-Held Printer
- B. Explanation of the information given in AM-48 Printouts

### A. AM-47 HAND-HELD PRINTER: OPERATION

See ¶3.9 and Figure 3-8 and 3-9 for a physical and functional description of the AM-47 Hand-Held Printer.

Paper Roll Installation. Refer to Figure 3-9.

1. For additional rolls of paper, order Part No. 26-0014.
2. Push up on the end of the housing (as indicated by arrow) to remove Paper Roll Compartment cover.

3. As illustrated in Figure 3-9:
  - a) Install Paper Roll.
  - b) Feed paper into slot.
  - c) Push [PAPER ADVANCE] button to route paper through.
4. Re-install compartment cover.

Self Test. For a printout of all possible characters:

1. Simultaneously hold down the [PAPER ADVANCE] button and set the Power Switch ON.
2. Self-Test printouts will be output for as long as the [PAPER ADVANCE] button is held down continuously (from the time power is first turned ON).

Charging Considerations. The AM-47 NiCad battery pack is charged through the AC Adapter (70-0029); see Figure 6-3 for connection.

Note the following concerning the charging process:

1. Charging is controlled by a microprocessor that is programmed to run the charging circuitry without sensing the actual charged or discharged state of the battery pack.
2. With the AC Adapter connected, each time the power is turned ON, the microprocessor assumes the worst case and goes into a full 14-hour charge cycle.
3. With the AC Adapter connected and the power OFF, the AM-47 is charged with a very low trickle current which takes several days to charge the battery pack.

**Note:** The AC Adapter is only for charging the batteries. If batteries are dead, the AC Adapter will not power the unit. Carefully observe that the AM-47 is normally charged with the Power ON, even though many other devices are typically charged with the power OFF.

4. The AC Adapter can be left continuously connected to the AM-47. There is no danger of “overcharging” the battery pack.
5. There are two (2) charging procedures:
  - a) A normal procedure.
  - b) A procedure if the battery pack is completely discharged.
6. After the charging cycle, the POWER LED will blink. A timer is also set which will start the charge cycle again after it has decremented to zero. Each time a line is printed, the timer is decremented a certain amount. If the POWER Switch is left ON, the AM-47 can print about 10,000 lines before the timer decrements to zero and a new charge cycle is initiated.

#### Normal Charging Procedure

1. Connect the AC Adapter (70-0029) as shown in Figure 6-3.
2. Turn the POWER Switch ON.
3. The POWER LED will light, indicating charging. (If the LED does not light, the Battery Pack is completely discharged. Go to the next procedure.
4. When the charging cycle is complete (after about 14 hours), the POWER LED will blink.

**Note:** Each time power is turned ON with the AC Adapter connected, the AM-47 will go through a complete charging cycle, regardless of the charge of the battery pack.

Charging Procedure When Battery Pack Completely Discharged

1. Connect the AC Adapter (70-0029) as shown in Figure 6-3.
2. Turn the POWER Switch ON to confirm Battery Pack is completely discharged.
3. If Battery Pack is completely discharged, the POWER LED will not light.
4. Turn the POWER Switch OFF. This will initiate a trickle charge that will charge the Battery Pack enough to operate the microprocessor-controlled charging circuitry.
5. Leave the POWER Switch OFF for about one (1) hour.
6. Turn the POWER Switch ON.
7. The POWER LED will now light continuously, indicating that the full charge cycle has begun.
8. After about 14 hours, the POWER LED will start to blink, indicating charging is complete.

Ribbon Cartridge Replacement. Refer to Figure 3-9.

1. For replacement Ribbon Cartridges, order Part No. 26-0015.
2. Push up on end of housing to remove Paper Roll Compartment cover.
3. See Figure 3-9:
  - a) Observe how the ribbon is routed on the old cartridge.
  - b) Push on the end of the cartridge (as indicated) to eject the old cartridge.

- c) Snap in the new cartridge, being careful to insert the ribbon correctly.
  - d) Rotate the manual Ribbon Take-Up to apply tension to the ribbon.
4. Re-install the Compartment Cover.

## B. AM-48 PRINTOUTS

Connect the AM-47 Hand-Held Printer or other printer to the AM-48 per ¶6.3 and Figure 6-3. There are two (2) methods to obtain an AM-48 printout:

1. Momentarily press Switch 9 to <PRINT> to get a printout on demand.
2. During a timed study (Impulse Noise or Transient Tests), there is an automatic printout every 15 minutes, as well as at the end of the timed study.

**Note:** The content of a printout depends on what mode is being displayed at the time of the printout.

Figures 7-11 thru 7-13 show the switch setups and sample printouts for each SEND and MEASURE mode. Note:

1. For modes with more than one display, a printout can be made from any display of the selected mode.
2. Printouts are shown exactly as they are output by the AM-47 Hand-Held Printer, in a 24-column format. When there is more than one (1) row to a printout, the rows after the first are indented by one (1) space.

3. In the NOTES column, the title of the printout is underlined and variable parameters are defined in the parentheses next to their printout. Definitions for more than one parameter are separated by a slash, “/”. Units of measurement are given only if not shown in the printout.
4. Asterisks, “\*” or “\*\*”, are used to reference notes.
5. For any measurements requiring a holding tone (HT), “HT-ON” indicates that the holding tone cursor was darkened at the time of the printout, meaning the measurement is valid. “HT-OFF” means an invalid measurement because the holding tone was not to specification.
6. The CMSG filter is shown in each printout of a measurement requiring a noise-weighting filter. 3K, 15K, or PROG (also PSHO or SWTD for AM-48E) would appear in this same position of the readout if one of these filters were selected.
7. Noise levels and thresholds are in “dBrn”, which applies to the AM-48 only; units would be “dBm” for the AM-48E.
8. “OVER” or “UNDER” readings could appear for any level measurement – only some samples are shown. These out-of-range indications are based on the Absolute reading, even for Relative printouts. “OVER” will print out for levels received greater than +10.9 dBm, and “UNDER” will print out for levels lower than –65.0 dBm. For Send and Measure ranges of values, See Figure 7-1 thru 7-9 in the tables next to the displays.
9. An example of the meaning of Relative measurements is shown in Figure 7-13. In the second entry, “+ 5.1rel-12.3” means “+5.1 dB relative to –12.3 dBm” (the reading when Switch 2 was set from <ABS> to <REL>).

10. In Figure 7-13, Relative noise printouts are possible for IMPLS and TRANS cursor settings. These are the same as the Relative noise measurements shown in Figure 7-13 printouts which start with “HZ” and “NN”.

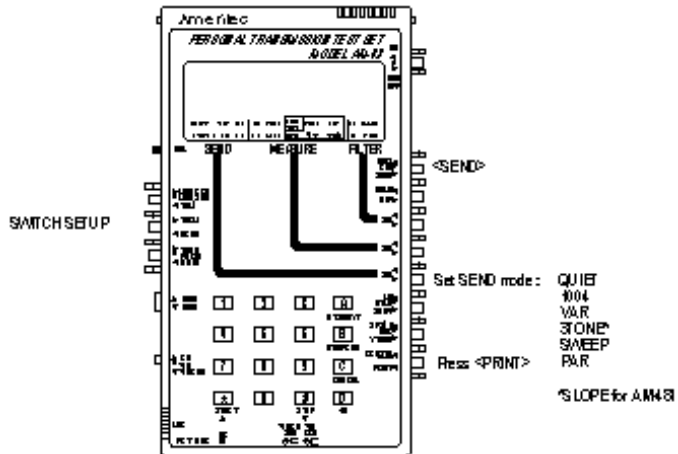

SEND CURSOR	SAMPLE PRINTOUT	NOTES (variable parameters defined in parentheses)
QUIET	SND QUIET	Send Quiet Termination
1004	SND 1004 HT +00.0dBm	Send 1004 Hz Tone (Level) HT = Holding Tone
VAR	SND 15000Hz -10.0dBm	Send Continuous Tone (Frequency/Level)
3TONE (SLOPE for AM-48E)	SND 3TONE* -15.0dB	Send 404, 1004, 2804, Hz (AM-48E: 404, 1004, 2004, 3004 Hz) Tones 5 Sec Duration (Level) *SLOPE for AM-48E
SWEEP	SND SWEEP +00.0dBm 204Hz-19904Hz SFSKIP* 100 STEP 1.0 RATE	Send Programmed Sweep (Level) (Start frequency-Stop Frequency) *SFSKIP is printed only if Switch 8 set to <SF SKIP>

SEND CURSOR	SAMPLE PRINTOUT	NOTES (variable parameters defined in parentheses)
PAR	SND PAR -20.5dBm	Send Peak-to-Average Waveform (Level)

Figure 7-11. SEND Printouts

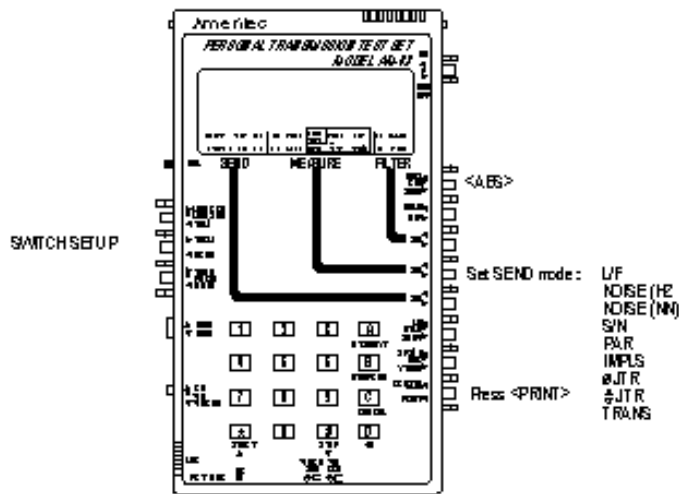

MEASURE CURSOR	SAMPLE PRINTOUT	NOTES (variable parameters defined in parentheses)
<u>L/F</u>	LF OVER dBm 1004Hz	<u>Measure Level/Frequency</u> Level is too high to measure
<u>L/F</u>	LF UNDERdBm 1004Hz	<u>Measure Level/Frequency</u> Level is too low to measure
<u>L/F</u>	LF +10.2dBm 12345Hz	<u>Measure Level/Frequency</u> (Level/Frequency)
<u>NOISE</u>	NZ +15.0dBm CM5G*	<u>Measure Idle Channel Noise</u> (Level) *Filter selected



MEASURE CURSOR	SAMPLE PRINTOUT	NOTES (variable parameters defined in parentheses)
<u>NOISE</u>	NN +12.0dBm CMSG* 1020HT=ON**	<u>Measure Notched Noise</u> (Level) *Filter selected **Valid Measurement
<u>NOISE</u>	NN +12.0dBm CMSG* 980HT=OFF**	<u>Measure Notched Noise</u> (Level) *Filter selected **Invalid Measurement
<u>S/N</u>	SN +50.0dB CMSG* 1000HT=ON**	<u>Measure Signal-to-Noise Ratio</u> (Difference between levels of holding tone and notched noise) *Filter selected **Valid Measurement
<u>PAR</u>	PAR -15.7dBm 85par	<u>Measure Peak-to-Average Ratio</u> (Level/Received PAR Reading)
<u>IMPLS</u>	IMP 15.0DUR 11.4TIM THLD 80dBm DELTA 2dB BLANKING 125ms CMSG* 7654LO 4321MID 1234HI	<u>Measure Idle Channel Impulse Noise</u> (Duration/Elapsed Time, minutes) (Low Threshold/Threshold Diff.) (Blanking Interval) (Low/Mid/Hi Impulse Noise Counts) *Filter Selected
<u>ØJTR</u>	PHJTR+17.2 RANGE 4-300 1000HT=ON* 999.6 PLL	<u>Measure Phase Jitter</u> (P/P Phase Jitter,%Bandwidth,HZ) (Phase-Locked-Loop Frequency,HZ) *Valid Measurement
<u>JTR</u>	AMJTR+14.8% RANGE 20-300 998HT=ON*	<u>Measure Amplitude Jitter</u> (P/P Amplitude Jitter/Bandwidth,HZ) *Valid Measurement

MEASURE CURSOR	SAMPLE PRINTOUT	NOTES (variable parameters defined in parentheses)
<u>TRANS</u>	TRAN 60.0DUR 45.0TIM THLD 100dBm DELTA 4dB BLANKING 125ms CMSG* 7645LO 5113MID 1538HI PTHLD 30 PHIT 2234 GTHLD 3 GHIT 1077 DROP 16 1008HT=ON** 1007.7 PLL	<u>Transient Test Run</u> (Duration/Elapsed Time, minutes) (Low Threshold/Threshold Diff.) (Blanking Interval) (Low/Mid/Hi Impulse Noise Counts) (Phase Hit Threshold,%Phase Hits) (Gain Hit Threshold,dB/Gain Hits) (Number of Dropouts) (Phase-Locked-Loop Frequency,HZ) *Filter Selected **Valid Measurement

Figure 7-12. MEASURE Printouts, Absolute Measure Mode

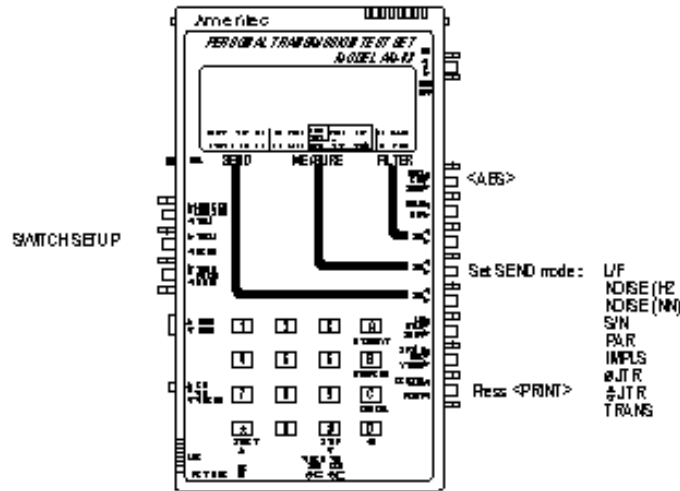

MEASURE CURSOR	SAMPLE PRINTOUT	NOTES (variable parameters defined in parentheses)
<u>L/F</u>	LF OVER rel+ 7.5 1234Hz	Level is too high to measure
<u>L/F</u>	LF + 5.1rel-12.3 1650Hz	<u>Measure Relative Level and Frequency</u> (Relative Level,dB/Reference Level,dBm/Frequency)

MEASURE CURSOR	SAMPLE PRINTOUT	NOTES (variable parameters defined in parentheses)
<u>NOISE</u>	NZ + 4.0rel+67.0 CMSG	Measure <u>Relative Idle Channel Noise</u> (Relative Level,dB/Reference Level,dBrn) *Filter selected
<u>NOISE</u>	NN - 3.0rel+54.0 CMSG 1000HT=ON**	Measure <u>Relative Notched Noise</u> (Relative Level,dB/Reference Level,dBrn) *Filter selected **Valid Measurement
<u>S/N</u>	SN + 1.0rel+45.0 CMSG 997HT=ON**	Measure <u>Relative Signal-to-Noise Ratio</u> (Rel. S/N Ratio,dB/ Ref. S/N Ratio,dB) *Filter selected **Valid Measurement
<u>PAR</u>	PAR + 2.3rel-40.6 72par	Measure <u>Relative PAR Level</u> (Relative PAR Level,dB/ Reference PAR Level,dBrn/ PAR Reading)

Figure 7-13. MEASURE Printouts, Relative Measure Mode

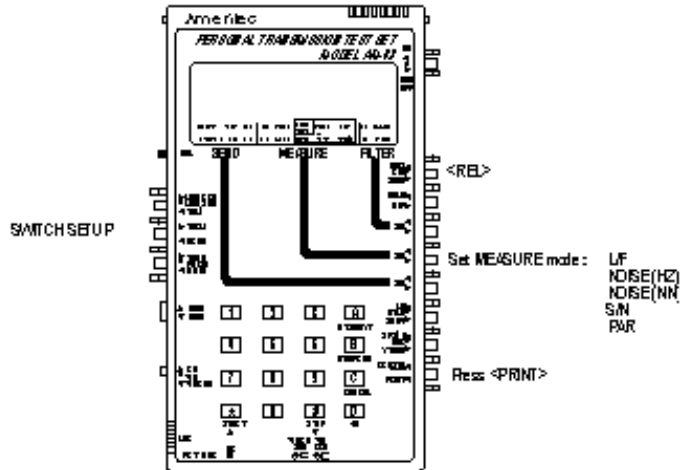

## 7.40 Auto Study Result Save

At the end of timed study (impulse or transient test), the AM-48 automatically stores the results and associated setup parameters in non-volatile memory. Whenever the AM-48 is turned on, the results of the last impulse or transient study are automatically recalled. The following measurements and parameters are automatically stored and recalled:

Impulse LO count	Impulse MID count
Impulse HI count	Phase hit count
Gain hit count	Dropout count
Elapsed time	Impulse threshold
Impulse delta threshold	Phase hit threshold
Gain hit threshold	

Note that parameter setting will not be stored if the [START] key is not pressed to actually run the impulse or transient test. Only the results of the last timed test that was run are stored.

Timed tests are not affected by the automatic power shutdown feature. The AM-48 will not turn itself off while an impulse or transient study is in progress. The power-off timer is reset to maximum time when [START] is pressed and does not operate during the study. As soon as the study is over, the power-off timer starts running with maximum time.

## 7.41 Impedance Adapter Measurement Corrections

The Impedance Adapter is illustrated in Figure 3-10. Figure 9-2 illustrates the Impedance Adapter's schematic diagram. See ¶6.5 for connection instructions. When the line is connected to the AM-48 through the Impedance Adapter, the display reading needs to be corrected.

Table 7-8 lists the correction values to add to or subtract from the value on the display. To calculate the correct level on the line, add the correction value to a MEASURE level or noise display reading (Switch 2 in <ABS> or <REL>); subtract the correction value from a SEND level display reading (Switch 2 in <SEND>).

**Table 7-8. Impedance Adapter Correction Values**

IMPEDANCE ADAPTER SETTING	CORRECTION VALUE
1200 OHM	3.0 dB
900 OHM	1.8 dB
THRU (600 OHM)	0 dB
150 OHM	6.0 dB
135 OHM	6.5 dB
75 OHM	9.0 dB

Memory Aid. To remember whether to add or subtract the correction value, it is helpful to think of the Impedance Adapter as introducing loss. the signal out of the Impedance Adapter is thus less than the signal into it. Refer to Figure 7-14.

For an AM-48 SEND mode, the signal actually sent on the line (beyond the Impedance Adapter) is less than the signal sent from the AM-48 (as indicated on the display). The correction factor is thus subtracted from the display reading to give the actual level of the signal sent on the line.

For an AM-48 MEASURE mode, the signal received by the AM-48 (as indicated on the display) is less than the incoming level from the line. The correction factor is thus added to the display reading to give the actual level of the signal received at the line.

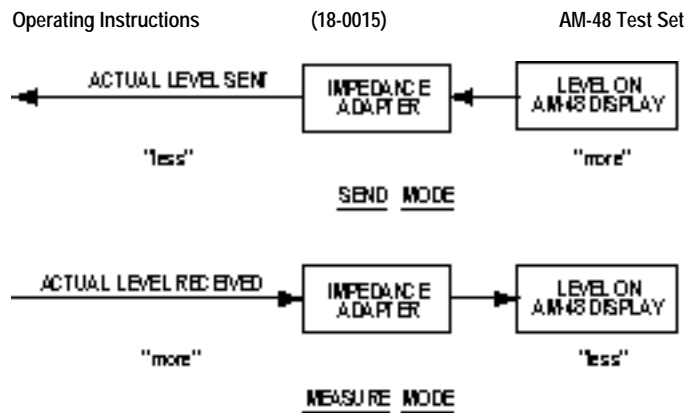

Think of the Impedance Adapter as introducing loss.

Figure 7-14. Impedance Adapter Correction Value Memory Aid

EXAMPLES. Refer to Table 7-8 for correction values (given in parentheses in the examples below).

1. Impedance Adapter set to 135 Ohms.
  - a) For AM-48 only:  
 Switch 2 in <ABS> and MEASURE cursor at (idle channel) NOISE. The display reads 60.0 dBm.  
 The correct reading is  $60 + (6.5) = 66.5$  dBm.  
For AM-48E only:  
 Switch 2 in <ABS> and MEASURE cursor at (idle channel) NOISE. The display reads -30.0 dBm.  
 The correct reading is  $-30 + (6.5) = -23.5$  dBm.
  - b) Switch 2 in <SEND> and SEND cursor at 1004. Level reading on display is -3.5 dBm.  
 The correct reading is  $-3.5 - (6.5) = -10.0$  dBm.

2. Impedance Adapter set to 1200 Ohms.
  - (a) Switch 2 in <ABS> and MEASURE cursor at L/F. Level reading on display is -20.0 dBm.  
The correct reading is  $-20.0 + (3.0) = -17.0$  dBm.
  - (b) Switch 2 in <SEND> and SEND cursor at PAR. Level reading on display is -3.0 dBm.  
The correct reading is  $-3.0 - (3.0) = -6.0$  dBm.

## 7.42 Auto Calibrate

**Note:** Auto-calibrate is only performed during servicing of the AM-48. The unit stays in calibration during normal operation..

Instructions to execute the AM-48 automatic self-calibrate:

1. Go to the QUIET SEND display, “\_\_\_\_\_ \_\_\_\_\_”, by setting switches as shown in Figure 7-15.
2. Press [C] and hold for about five (5) seconds.
3. The display responds with a series of prompts shown and explained in Figure 7-15.
4. Answer each prompt with “yes” or “no”.
  - a) Press [ETR/NEXT] for “yes”.
  - b) Press [CANCEL] for “no”, which aborts the auto calibrate sequence.
5. After the last prompt, the AM-48 will proceed with an auto calibrate of the measurement circuits.

DISPLAYS	NAME	CONDITION TO CHECK BEFORE PROCEEDING
AUTO CAL?	AUTO CAL?	Press [F/RNEXT] to proceed with Auto Calibrate. Press [F/ANCEIL] to abort.
ON HOOP?	ON HOOP?	Be sure holding circuit is on hook (Switch 42 in <ON HOOK>).
4 WIRE?	4 WIRE?	Be sure Switch 40 is in <4W> (or <4W REV>).
900 OHM?	900 OHM?	Be sure Switch 11 is in <900Ω>.
TERM?	TERM?	Be sure Switch 55 is in <TERM>.
LOOP?	LOOP?	Be sure a cable is installed to loop back the send pair to the receive pair (see Figure 5-1 for possible connection).

QUIET 100% WAF LUF NOISE **HOLD** NOISE SWN SK C-MSG  
 3 TONES SWEEP PAIR PAIR IMPULS **OUTR** **OUTR** TRANS 15K PROG

QUIET darkened

After each prompt, check that the indicated setup is made before pressing [F/RNEXT] to proceed. Press [F/ANCEIL] at any time to abort Auto Calibrate.

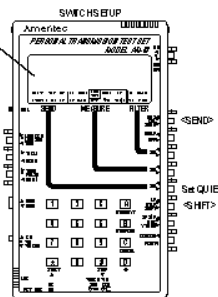

Figure 7-15. AM-48 Auto Calibrate Prompts



## 8. EXPLANATION AND APPLICATION OF MEASUREMENTS

### 8.1 Introduction

This section gives the theory behind the measurements whose operating instructions are described in Section 7. The meaning of the measurements and how they are used is discussed. This section is divided into the following paragraphs:

- 8.2 Units of Measurement
- 8.3 Level (Gain or Loss) and Frequency
- 8.4 Idle Channel Noise
- 8.5 Notched Noise (Noise with Tone)
- 8.6 Signal-to-Noise
- 8.7 PAR
- 8.8 Gain Slope
- 8.9 Idle Channel Impulse Noise
- 8.10 Phase Jitter
- 8.11 Amplitude Jitter
- 8.12 Notched Impulse Noise
- 8.13 Phase Hits
- 8.14 Gain Hits
- 8.15 Dropouts

### 8.2 Units of Measurement

As with any system of measurement, standard units of measurement have been established in transmission testing to enable you to meaningfully evaluate measurements and make comparisons of the results

This paragraph discusses units of measurement used in analog transmission level and noise measurements. Refer to Figure 8-1.

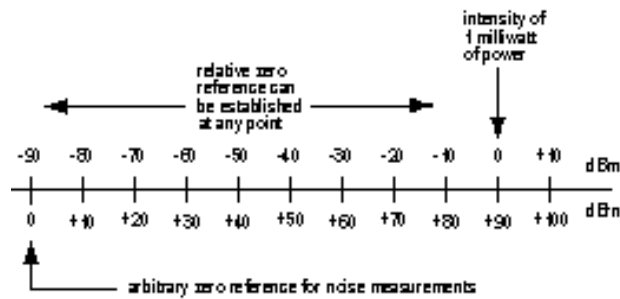

Figure 8-1. Level and Noise Units of Measurement

1. **dB**. The decibel (dB) is a logarithmic (base 10) electrical unit used to compare or indicate changes in level of intensity. The dB unit is only a unit of intensity, and does not have meaning unless a point of reference is established. Therefore, the systems of dBm and dBn were established as described below.
2. **dBm**. To establish a point of reference in making comparisons in level (and noise for CCITT standard) measurements in transmission testing, the system of dBm was adopted.

**00.0 dBm** is defined as the level of one (1) milliwatt of power, hence the abbreviation “m” after the dB. Levels of less intensity than this reference point are negative (-dBm) values, and levels of greater intensity are positive (+dBm).

It turns out that 00.0 dBm is a strong level for a telephone line, so most level measurements in units of dBm are negative, i.e., less intense than 00.0 dBm reference. For example, -10.0 dBm is a typical level at which dialing tones are sent.

3. dBm. The dBm unit is used in noise level measurements. “m” meaning “relative noise”. The zero reference for noise measurement has been established at -90.0 dBm, an extremely low level for a telephone line. Thus, noise measurements will always be positive (higher level) with respect to the 00.0 dBm reference.

Note that 00.0 dBm is the same as +90.0 dBm. This is shown in ¶5.4.d and e, and Figure 5-4, where a 00.0 dBm tone is looped back and measured as a “noise”. In real life, however, noise is measured on an idle line, or after notching out a holding tone.

4. Voltage to dB Conversion. The AM-48 makes level and frequency measurements by measuring the voltage appearing on the line. The internal microprocessor then converts this voltage reading to dBm or dBm by assuming that the line is terminated by either 600  $\Omega$  or 900  $\Omega$  as selected by Switch 11. The conversion is in accordance with the formula:

$$10 \times \text{LOG}_{10} [(1000) \times (V^2/Z)]$$

where:  $Z = 600 \Omega$  or  $900 \Omega$ , and  $V =$  measured voltage.

5. Absolute and Relative Measurements. An absolute level measurement is made in units of dBm. A relative (Rel) measurement is in units of dB Rel. A zero point of reference is established at any level, and subsequent level measurements are made relative to that level. See ¶7.22 for an explanation of how relative measurements are used.

### 8.3 Level (Loss or Gain) and Frequency

Level or frequency measurements are made by applying a tone of a known frequency and amplitude (normally 1004Hz @ 0.0 dBm) to the distant end of the transmission line being tested, and then measuring the received level and frequency at the near end. The difference between sent level and received level is the loss (or gain) introduced by the line. The difference in sent frequency and received frequency is the frequency offset introduced by the line.

### 8.4 Idle Channel Noise

These noise measurements are made through an internal noise-weighting (shaping) filter on a line under test without tone present.

One (1) of four (4) standard noise-weighting filters is selected for this test:

C-Message, C-MSG (Psophometric, PSHO, for AM-48E)

3-kHz, 3K

15-kHz, 15K

Program, PROG (Sound-weighted, SWTD, for AM-48E)

The distant end of the line being measured is normally “Quiet Terminated”, i.e., disconnected from the distant modem or terminal and connected to a resistive termination.

### 8.5 Notched Noise (Noise with Tone)

Far End. A notched noise measurement is made with a holding tone of a specific frequency (normally 1004Hz in North America) applied to the distant end of the line under test.

Near End. At the near end of the line, the AM-48 test set removes the holding tone by routing the received signal through a notch filter, and then passes the remaining noise through the selected noise-weighting filter before measuring its level.

Holding Tone. In order for measurement to be accurate, it is important for the received holding tone to be of the proper frequency and of adequate amplitude. A “HOLD TONE” indicator is provided in the AM-48. If it is darkened, the hold tone is of an acceptable frequency and level to ensure an accurate measurement. If the hold tone indicator is not on, the measurement is invalid.

## 8.6 Signal-to-Noise (S/N) Ratio

This test is also performed by applying a holding tone to the distant end of the line under test. At the near end, the AM-48:

1. Measures and remembers the level of the received signal (Holding Tone).
2. Notches out the Holding Tone, and measures the residual noise.
3. Displays the S/N ratio (the difference, in dB, of the two readings).

Note that if the noise component is largely independent of the hold tone signal level. The S/N ratio will then vary with the level of the transmitted hold tone. For this reason, it is important that the transmitted hold tone level be sent at the same level as the normal signal that appears on the line.

## 8.7 P/AR Measurements

Definition of P/AR. P/AR (Peak to Average Ratio) measurements are made by applying a special 16 tone (PAR) signal at the distant end of the line under test. At the near end, the AM-48 simultaneously measures the peak value and average value of the received test signal. The ratio of the Peak value to the Average value of the transmitted signal is arbitrarily assigned a value of 100.

If the transmission channel were non-dispersive, the received Peak-to-Average Ratio would also have a value of 100. A typical telephone channel, however, causes smearing or Intersymbol Interference, and a value of other than 100 is observed.

Table 8-1 shows some typical values that might be used to judge the acceptability of a telephone line to reliably transmit data.

Table 8-1. P/AR Requirements of Telephone Lines

CIRCUIT CONDITIONING	TYPICAL P/AR VALUES
BASIC CHANNEL	45
C1	48
C2	78
C4	87
C5	95

EXAMPLE: If a modem requires a C2 conditioned line and a P/AR of 50 is measured, the line is likely to encounter transmission problems. On the other hand, if a P/AR of 78 is measured, Intersymbol Interference will not present problems.

The P/AR value of the received (distorted) signal is made according to the following formula:

$$P/AR = 100 * (K P/Afw - 1)$$

Where: P = peak voltage of received signal

Afw = full-wave average of the received signal

K = a constant

The constant K is derived by giving an undistorted signal a nominal value of 100. Therefore:

$$K = 2S_{afwo}/P_o$$

Where:  $P_o$  = Peak voltage of the undistorted (original) signal

$A_{fwo}$  = full-wave average of the undistorted (original) signal

Therefore:  $P/AR = 100 * (2(P/P_o)/(A_{fw}/A_{fwo})-1)$

or  $P/AR = 100 * (2(P_n/A_{fwn})-1)$

Where:  $P_n$  = normalized peak voltage of the received signal

$A_{fwn}$  = normalized full-wave average of the received signal

Factors Which Affect P/AR. P/AR is most sensitive to envelope delay distortion and return loss problems. To a lesser degree, it is affected by attenuation distortion, noise, and nonlinear (intermodulation) distortion. It is basically unaffected by transient phenomena, such as impulse noise and phase and gain hits.

Envelope Delay Distortion. There is a high correlation between measured P/AR values and values calculated from a plot of envelope delay distortion. In fact, for an envelope delay response containing significant ripples, P/AR is a better indication of the ability of the network to pass data reliably. Return loss problems are a common source of envelope delay ripple.

Effect of Noise. Noise can have a significant effect on a P/AR measurement. For this reason, it is important to measure signal to noise ratio (or noise-with-tone) before making a P/AR measurement. If the signal-to-noise ratio is less than 25 dB, the P/AR reading will be significantly reduced by noise alone.

Effect of Nonlinear Distortion. Nonlinear (Intermodulation)

Distortion can similarly affect the P/AR reading. The effect depends on whether the second or third order products dominate as the source of the distortion. If the third order products dominate, they increase or decrease the P/AR value, depending upon the sign of the added products.

## 8.8 Gain Slope

Gain slope (sometimes referred to as attenuation distortion) measurements are similar to a level/frequency measurement, except that the level measurement is made at several different frequencies in order to determine the loss (or gain) on the line at different frequencies. The AM-48 SEND 3TONE will repeatedly send 5-second intervals each of 404 Hz, 1004 Hz, and 2804 Hz. The AM-48E SEND SLOPE will repeatedly send 5-second intervals each of 404 Hz, 1004 Hz, 2004 Hz, and 3004 Hz.

Because it is desirable to express the difference in loss at different frequencies, this measurement is usually done on a relative level basis. The two (2) methods that can be used with the AM-48 to measure gain slope are outlined below:

Gain Slope Using <ABS> Measure.

1. Set Switch 2 of near end AM-48 to <ABS>.
2. Read the level at the near end of the line while the far end AM-48 is in SEND 3TONE (SLOPE for AM-48E).
3. Note the least loss and most loss readings.
4. Calculate the difference between the least loss and most loss readings. This is the gain slope of the line.



Gain Slope Using <REL> Measure.

1. Start with Switch 2 of near end AM-48 to <ABS>.
2. Read the level at the near end of the line while the far end AM-48 is in SEND 3TONE (SLOPE for AM-48E).
3. Note the lowest absolute reading.
4. Set Switch 2 to <REL> when the display shows the lowest absolute reading.
5. The display will initially read zero, and all subsequent readings will be in DB REL, relative to the lowest absolute reading.

## 8.9 Idle Channel Impulse Noise

This is a timed study that counts the number of noise pulses that exceed each of three levels (thresholds). No Holding Tone is used for this test. The constraints of the test are first set up and then the test is run.

Information concerning the idle channel impulse noise test

1. Three (3) noise thresholds are established > low, middle, and high levels, with an equal interval between them, called the delta.
2. The time over which the run is to be made is set, called the duration.
3. The run is started, and a running count is kept of the number of noise pulses that exceed each threshold.
4. The run will automatically stop when the duration time is reached, or the test can be manually stopped at any previous time.
5. A blanking interval is set, during which time the noise pulse counter does not count.

**Blanking Interval.** The blanking interval for a threshold is started when a pulse exceeds the threshold for the first time. The noise pulse counter does not count during the blanking interval. The purpose of the blanking interval is to minimize the affect of ringing on the count. Without the blanking interval, several counts could be made immediately after the first pulse, due to secondary pulses caused by ringing. The blanking interval allows time for the ringing to die down.

Figure 8-2 illustrates example parameters and shows how the blanking intervals are initiated.

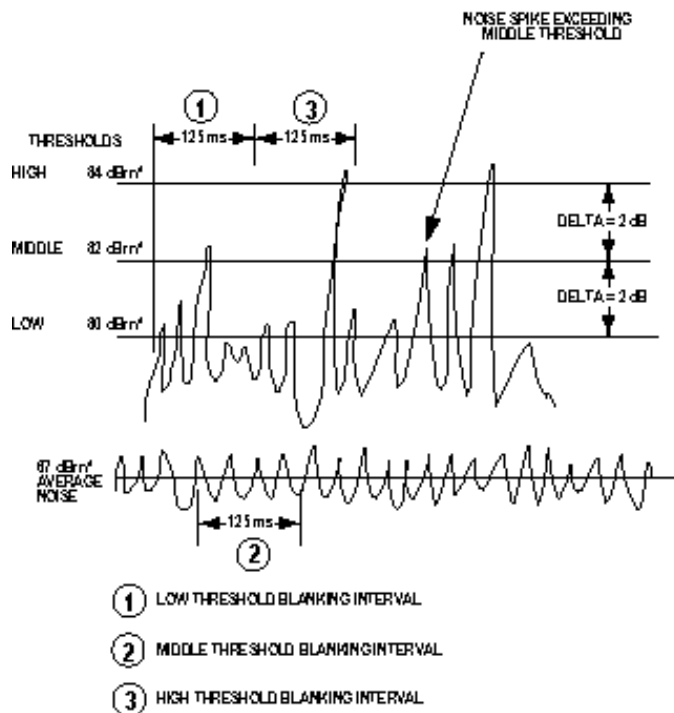

Figure 8-2. Impulse Noise Thresholds and Blanking Intervals

See the tables in Figure 7-6 for information on the ranges of the parameters. A typical duration time for the study is 15 minutes, although a study of up to 33 hours could be made. Note that only values for the low level and the delta are set, which determines all three (3) levels.

## 8.10 Phase Jitter

This measurement requires a 1004 Hz nominal Holding Tone. This test measures the peak-to-peak phase variation of the modulation of the holding tone. The bandpass (range of frequencies) is selected, over which the phase jitter is to be measured. A phase-locked-loop generator locks on to the Holding Tone and an average peak-to-peak phase jitter is measured in degrees.

The bandpass (bandwidth) can be set to either:

- 4 Hz to 300 Hz or
- 20 Hz to 300 Hz

The exact frequency of the Holding Tone is known because it is the same as the displayed phase-locked-loop frequency.

## 8.11 Amplitude Jitter

The test setup for amplitude jitter is the same as the phase jitter measurement (§8.10) except that instead of measuring the variation of the phase, the variation of the amplitude of the modulation is measured. The unit of measurement for the amplitude jitter is average percent peak-to-peak variation.

Since this is an amplitude measurement, the phase-locked-loop frequency is not of interest.

### 8.12 Notched Impulse Noise

This test is the same as the Idle Channel Impulse Noise Test, ¶8.9, except that it is made over an active line with a holding tone which is notched out before the measurements are performed.

### 8.13 Phase Hits

A phase hit is a sudden change in the phase of the modulation of a Holding Tone. A threshold of from 5 to 45 degrees is set, and the number of phase hits that exceed that threshold during the timed study is counted.

### 8.14 Gain Hits

A gain hit is a sudden change in the amplitude of the modulation of a Holding Tone. A threshold of 2, 3, 4, or 6 dB is set, and the number of gain hits that exceed that threshold during the timed study is counted.

### 8.15 Dropouts

A dropout is the loss of the Holding Tone. The number of losses of the Holding Tone during a timed study is counted. A “loss” of the Holding Tone occurs if the Holding Tone level and/or frequency go out of the acceptable range for valid transient measurements.

## 9. CIRCUIT DIAGRAMS

### 9.1 Introduction

This section covers a block diagram of the AM-48 and a schematic diagram of the Impedance Adapter.

### 9.2 AM-48 Simplified Block Diagram

Figure 9-1 is a simplified block diagram of the AM-48. Note that continuous lines connecting the blocks indicate signal paths, while broken lines indicate control paths. The definitions of the abbreviations in the block diagram are listed below.

<b>AMP</b>	AMPlifier	<b>AV</b>	Average detector
<b>AUTO</b>	AUTOMatic	<b>BP</b>	1 KHz Band Pass filter
<b>CMSG</b>	C-message noise-weighting filter		
<b>DET</b>	DETEctor	<b>FILT</b>	FILTer
<b>FWR</b>	Full Wave Rectifier	<b>HOLD</b>	HOLDing circuit
<b>4 HZ</b>	4 Hz high pass filter	<b>20 HZ</b>	20 Hz high pass filter
<b>300 HZ</b>	300 Hz low pass filter	<b>IMPLS</b>	IMPuLSe
<b>MIC</b>	MICROphone	<b>MUX</b>	MultipleXor
<b>NTCH</b>	1010 Hz NoTCH filter		
<b>PAR</b>	Peak-to-Average Ratio filter (1300 Hz bandpass)		
<b>PK</b>	PeaK detector	<b>P/P</b>	Peak-to-Peak detector
<b>PROG</b>	PROGram noise-weighting filter		
<b>QUIET</b>	QUIET termination	<b>R</b>	Ring
<b>RCV</b>	ReCeIve		
<b>RMS</b>	RMS (Root Mean Square) detector (for noise)		
<b>SKR</b>	SpeaKeR	<b>SND</b>	SeND
<b>SW</b>	Switch	<b>T</b>	Tip
<b>V/F</b>	Voltage-to-Frequency converter		
<b>2W</b>	2-Wire	<b>4W</b>	\$.Wire

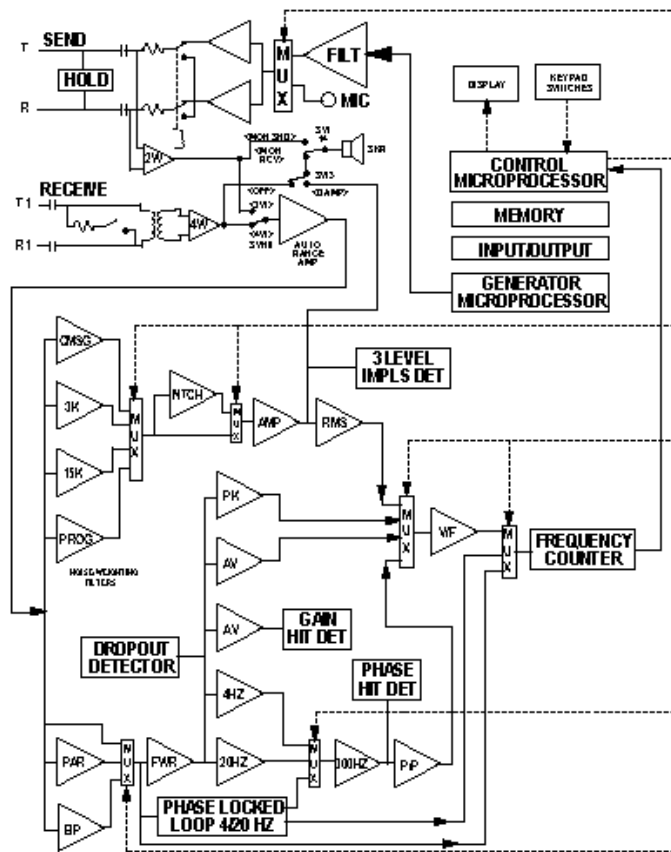

Figure 9-1. Simplified Block Diagram of the AM-48

### 9.3 Impedance Adapter Schematic

Figure 9-2 is a schematic diagram of the Impedance Adapter, Model Number 24-0008.

See Figure 3-10 for an illustration of the Impedance Adapter. Also see ¶3.10, ¶6.5, and ¶7.41 concerning the Impedance Adapter.

Note the following in the schematic shown in Figure 9-2:

1. The upper circuitry (2W or 4W Send) is identical to the lower circuitry (4W Receive).
2. Switch S1 is controlled by the upper knob of the Impedance Adapter; Switch S2 is controlled by the lower knob.
3. Impedance Adapter switch positions (THRU, 1200, 900, 150, 135, and 75) are indicated on the upper poles of S1 and S2.
4. The internal impedance of the AM-48 is set for 600 Ohms. Therefore, for impedance greater than 600 Ohms, the Impedance Adapter adds resistance in series to give the correct impedance. For impedance less than 600 Ohms, the Impedance Adapter connects an appropriate resistance in parallel to give the correct impedance.

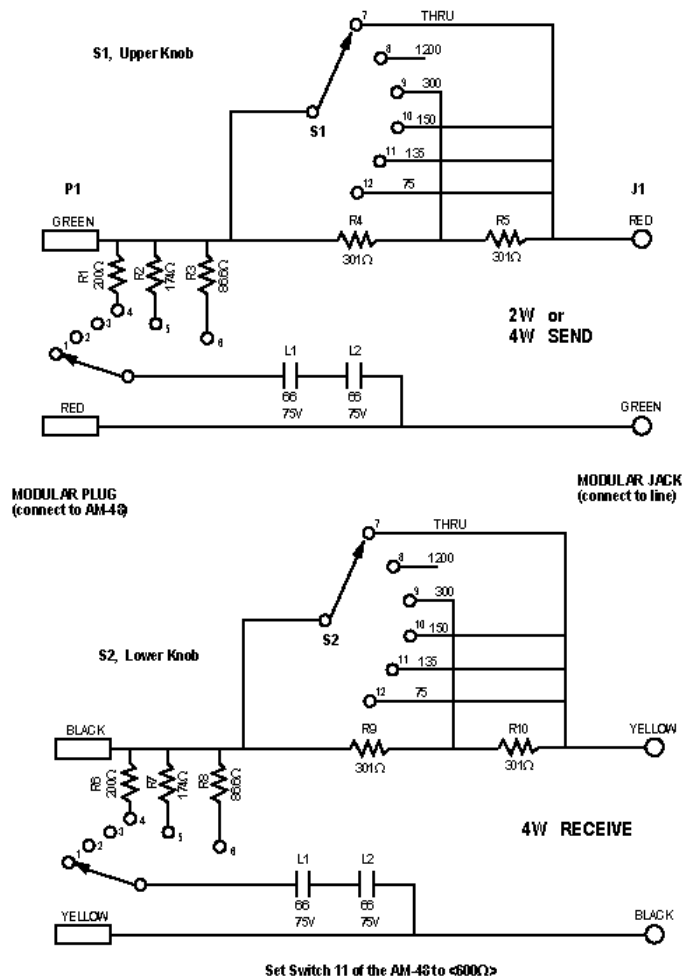

Figure 9-2. Schematic Diagram of the Impedance Adapter



## **10. WARRANTY, SERVICE, & CALIBRATION**

### **10.1 Warranty**

AMERITEC Corporation warrants that its electronic instrument products are manufactured to the highest commercial standards and are free from any defects in material or workmanship.

For a period of one (1) year from shipment, AMERITEC will repair, without charge to the original purchaser, any unit which upon inspection by AMERITEC proves to be defective.

This warranty is the sole warranty offered by AMERITEC and is in lieu of all other obligations or liabilities, including claims of consequential damage; however, an EXTENDED WARRANTY PLAN may be purchased. For information contact an AMERITEC Sales Representative.

### **10.2 Service Policy**

AMERITEC products are designed with plug-in printed circuit boards and modular assemblies. Once a problem is localized, service is accomplished by PC board (or module) replacement.

### **10.3 Calibration Policy**

All AMERITEC products are manufactured to commercial standards and are calibrated with equipment traceable to NIST (National Institute of Standards and Technology). With the exception of component failures or abuse, AMERITEC instruments are designed to maintain compliance with their published specifications throughout their service life.

While periodic calibration verification is normally not required, in critical applications it is recommended that verification be accomplished annually.

Warranty

(18-0015)

AM-48 Test Set

Calibration verification is most efficiently accomplished by return of the equipment to the AMERITEC factory where specialized test equipment is used. Field calibration verification is not supported by AMERITEC.

## 10.4 Return of Unit

In the event of a malfunction, call or write to the AMERITEC factory and obtain a return authorization number.

Return the unit to AMERITEC, freight prepaid, with a note (in-warranty repair) or a Purchase Order for the repair (out-of-warranty repair) listing the following information:

- Return authorization number from AMERITEC.
- Return shipment address of purchaser.
- Name and telephone number of person at purchaser's location who is familiar with the problem.
- Brief description of problem. (Include any printouts that may have a bearing on the problem, if possible.)
- Terms of payment of repair costs (out-of-warranty unit).

The unit will be repaired and returned freight-prepaid for units in warranty and freight-collect for out-of-warranty units.

As stated above, a Purchase Order to cover the cost of repair must accompany any out-of-warranty return of the unit to AMERITEC.

**Ameritec**  
CORPORATION  
760 Arrow Grand Circle  
Covina, CA 91722 USA  
TEL 626.915.5441  
FAX 626.915.7181  
www.ameritec.com

## 11. GLOSSARY

Nomenclature. This manual uses consistent nomenclature to refer to the cursor settings, switches, jacks, keys, and displays. The writing of the reference is exactly the same as it appears on the AM-48. The different components are distinguished by underlining, or enclosing in angular brackets, square brackets, or quotation marks. The table below gives examples of each type of notation:

COMPONENTS	EXAMPLE NOTATIONS
Cursor Settings	<u>QUIET</u> , <u>L/F</u> , <u>PROG</u> , <u>IMPLS</u>
Switches and Jacks	<ABS>, <ON HK>, <EAR>, <RCV>
Keys	[7], [ETR/NEXT], [#], [START]
Displays	"LEVL", "-10.0 DBM", "400 HZ"

The balance of this GLOSSARY is an alphabetical listing of the terms and abbreviations used in this manual along with their definitions.

ACRONYM	COMPLETE TERM or DEFINITION
<ABS>	Switch position to give ABSolute measurement readings.
AC	Alternating Current
AM	Ameritec Corporation
AMJTR	Amplitude JiTteR
"BLANC"	Blanking interval, used in timed tests.
<BRDG>	Switch position to BriDGe the line connections.
"Butt Set"	Portable piece of telephone test equipment with capability of dialing, talking, and listening.
[CANCEL]	Key used to clear an undesired parameter value from the display. Display reverts to previous value.
CCITT	Consultative Committee on International Telegraphy and Telephony
C-MSG	C-MeSsaGe noise-weighting filter

ACRONYM	COMPLETE TERM or DEFINITION
CO	Central (telephone) Office
CPU	Central Processing Unit
D	Depth
<DAMP>	This switch setting slows down the display update to 2 times per second (instead of 4 times per second for <OFF> setting).
dB	decibels
dBm	decibels relative to 1 mw
dBrn	decibels of relative noise (0 dbrn = -90 dbm)
DC	Direct Current
<DC 9V>	Plug for AC Adapter.
"DROP"	Number of DROPOuts.
DTE	Data Terminal Equipment
DTMF	Dual Tone Multi-Frequency
"DUR"	DURation for timed tests.
<EAR>	EARphone jack
EIA	Electronics Industries Association (USA)
[ETR/NEXT]	EnTeR/NEXT display. This key is used to either EnTeR a value into memory or to go to the NEXT display.
[ETR/PREV]	EnTeR/PREV display. This key is used to either EnTeR a value into memory or to go to the PREVIOUS display.
FX	Foreign eXchange
"GHIT"	Gain HIT count
"GTHLD"	Gain hit THreshoLD
H	Height
Holding Tone (HT)	A 1004 Hz tone used to simulate a signal on the line. The Holding Tone is notched out by a filter to allow measurement of associated noise.
HT	Holding Tone
Hz	Hertz (cycles per seconds)
"IDELTA"	Impulse DELTA, i.e., difference between thresholds.

ACRONYM	COMPLETE TERM or DEFINITION
IHI	High Impulse noise count
"ILO"	Low Impulse noise count
"IMID"	MIDdle Impulse noise count
<u>IMPLS</u>	IMPuLSe Noise (timed test)
"ITHLD"	Impulse THreshoLD
Jack	Female connector
"JITR"	Jitter
<u>I JTR</u>	Amplitude Jitter
<u>Ø JTR</u>	Phase Jitter
3K	3 kHz noise-weighting filter
15K	15 kHz noise-weighting filter
kHz	Kilo-Hertz, 1000 Hz
LED	Light-Emitting Diode
"LEVL"	Level
<u>L/F</u>	Level/Frequency
MF	Multi-Frequency
<MIC>	Microphone
MIN	MINute
mm	Millimeter (.001 meter)
MODEM	MODulator/DEModulator
<MON RCV>	MONitor ReCeIve pair (with the speaker)
<MON SND>	MONitor SeND pair (with the speaker)
ms	Milliseconds
MW	Milliwatt, i.e., a source @ 0dBm and 1004 Hz.
NiCad	Nickel Cadmium. A type of battery.
NN	Notched Noise
<NOR>	Normal. Switch position to allow generation of all frequencies.
Notch Filter	A filter which greatly attenuates a signal at a certain frequency called the notch frequency, e.g., 1010 Hz, used for notched noise measurements.
NZ	NoiZe, i.e., idle channel noise.

ACRONYM	COMPLETE TERM or DEFINITION
<OFF>	This is the normal switch setting to give a display update of 4 times per second.
<ON HK>	Switch position for ON Hook.
"OVER"	Level is OVER maximum measurable level.
<u>PAR</u>	Peak-to-Average Ratio
PHJTR	Phase JiTeR
"PLL"	Phase-Locked Loop frequency
Plug	Male connector
P/P	Peak-to-Peak
PPS	Pulses Per Second
<PRINT>	Print. Switch position to give printed copy of setup and measurements.
<u>PROG</u>	PROGram noise-weighting filter. This term comes from radio broadcasting where a PROGram filter was developed to simulate the effect of transmitting a radio PROGram to a remote transmission tower.
<PRT>	Printer port jack.
<u>PSHO</u>	PsopHometric noise-weighting filter
"PTHLD"	Phase hit ThreshoLD
<PULSE>	Switch position for PULSE dialing.
<u>QUIET</u>	Quiet termination
R, R1	Ring: the connection at the ring of e.g., a Bantam connector.
"RANGE"	Frequency bandwidth RANGE for jitter measurements.
<RCL/STO>	ReCaLI/STOre. Switch position to store/recall information from non-volatile memory.
<RCV>	ReCeIve jack
Ref	Reference
<REL>	Switch position to give RELative measurement readings.
RJ11	6-wide modular connector
RS232	Standard EIA interface using 25-pin D connector.
<SEL>	SElect

ACRONYM	COMPLETE TERM or DEFINITION
<SEND>	Switch position to monitor SEND signal on display.
<SF SKP>	Signaling Frequency SKIP. Switch position to prevent generation of tones in the signaling band.
<SHIFT>	Switch position to enable auxiliary keyboard functions.
<u>SLOPE</u>	For AM-48E only, pre-programmed set of tones (304 Hz, 1004 Hz, 2004 Hz, 3004 Hz) which are sent in a cycle for 5 second intervals. See <u>3TONE</u> for AM-48.
S/N	Signal-to-Noise ratio
<SND>	SeND jack
S/S	Starting and Stopping of a timed test.
[START]	Key used to start a timed test.
[STOP]	Key used to stop a timed test.
"STUC"	Stuck. Display indication that sweep is programmed for only one frequency.
<u>SWEEP</u>	A programmable series of frequencies are sent in steps.
<u>SWTD</u>	Sound-WeighTeD noise-weighting filter
T, T1	Tip. The connection at the tip of e.g., a Bantam connector.
<TALK>	"Push-to-TALK" switch
<TERM>	TERMinate: switch position to terminate line connections.
THLD	ThreshoLD
"THLD 2 HI"	Display indication that upper ThreshoLD is too High (in impulse noise timed test).
TIE	TIE line of a telephone network.
"TIME"	Elapsed time for timed tests.
"TMOFF"	TiMe OFF. Time after which AM-48 will automatically turn itself off when unit is left unattended.
<u>3TONE</u>	For AM-48 only, pre-programmed set of tones (404 Hz, 1004 Hz, 2804 Hz) which are sent in a cycle for 5 second intervals. See <u>SLOPE</u> for AM-48E.
TRAN	TRANsient test

ACRONYM	COMPLETE TERM or DEFINITION
TRANS	TRANSient test, i.e., a timed test measuring impulse noise, gain hits, phase hits, dropouts.
"TTLEV"	Touch Tone LEVEL
"UNDR"	Level is UNDeR minimum measurable level.
V	Volts DC
<u>VAR</u>	Variable (level and frequency) tone
<VOL>	VOLUME control. Controls level of speaker volume.
W	Width
WECO	Western Electric Company
2W	2-wire
4W	4-wire
<4W REV>	Switch position to frog 4-wire connections, i.e., to switch the receive and send pair connections.
XMIT	Transmit
<X TONE>	Auxiliary Tone, 2713 Hz.



## INDEX

### #

± .....	3-16
1004 Hz .....	1-6
16-Key Array .....	3-15
2-Wire AM-48 Line Connections .....	6-3
2-Wire Measurements .....	7-23
2-Wire Network Testing with Responders .....	6-14
2W .....	3-10, 6-6
3-Tone .....	1-7
4-Wire AM-48 Line Connections .....	6-4
4-Wire End-to-End Testing .....	6-11
4-Wire Testing with Responder .....	6-13
4W .....	3-11, 6-6
4W REV .....	3-11
600 .....	3-11, 6-8
600 /900 Line Termination Impedances .....	6-7
900 .....	3-11, 6-8

### A

Abbreviations .....	9-1
ABS .....	3-8, 7-23
Absolute and Relative Measurements .....	7-23, 8-3
AC Adapter .....	6-2
AC Power .....	4-4
Acceptable Holding Tone Ranges .....	7-25
Accuracy of Measurements .....	7-22

Index	(18-0015)	AM-48 Test Set
ALKALINE.....		4-2
Alkaline Batteries.....		4-3
AM-47 Hand-Held Printer Connection with AC Power.....		6-5
AM-47 Hand-Held Printer Technical Specifications.....		3-21
AM-48 Auto Calibrate Prompts .....		7-60
AM-48 Connectors.....		3-4
AM-48 General Technical Specifications.....		1-5
AM-48 Generator (Send) Technical Specifications .....		1-6
AM-48 Interface with Line Connections.....		6-6
AM-48 Keyboard Identification Numbers.....		3-15
AM-48 Liquid Crystal Display .....		3-18
AM-48 Location of Components.....		3-3
AM-48 Optional Equipment.....		2-2
AM-48 Polarity .....		6-6
AM-48 Power/Physical Technical Specifications.....		1-11
AM-48 Receiver (Measure) Technical Specifications.....		1-8
AM-48 SEND, MEASURE, and FILTER Menus .....		3-19
AM-48 Setup for Self-Test (Looped Back).....		5-2
AM-48 Simplified Block Diagram.....		9-1
AM-48 Standard Equipment.....		2-2
AM-48 Switch Identification Numbers.....		3-6
AM-48 Technical Specifications .....		1-4
AM-48E Technical Specifications .....		1-11
Amplitude Jitter.....		1-9, 8-11
Auto Calibrate.....		7-59
Auto Study Result Save.....		7-56
Automatic Power Shutdown.....		4-4
Aux Tone .....		1-7
Auxiliary Functions.....		3-14

**B**

Battery Compartment.....7-17  
Battery Information ..... 4-3  
Battery Installation ..... 4-3  
Battery Installation and Selector Switch..... 4-2  
Battery-Selector Switch..... 4-1  
Blanking Interval .....8-10  
BRDG .....3-12, 6-8  
Butt Set..... 1-3

**C**

Cable Connection..... 5-1  
Calibration Policy .....10-1  
CANCEL .....3-16  
Charging Considerations .....7-46  
Charging Procedure when Battery Pack Discharged.....7-48  
Check List ..... 7-3  
Circuit Diagrams..... 9-1  
Color Coding .....7-25  
Component Location ..... 3-2  
Configurations.....6-10  
Connection and Configuration ..... 6-1  
Connectors and Cables..... 3-3, 6-2  
Continuous Power On..... 4-5  
Continuous Tone.....7-14  
Cursor Setting ..... 7-5

**D**

DAMP.....	3-8
Damping .....	1-10
dB.....	8-2
dBm .....	8-2
dBm .....	8-3
Default Parameter Settings for SWEEP Send Mode .....	5-14
Definition and Purpose.....	1-2
Dial.....	1-5
Dialing.....	5-8, 5-10, 7-43
Dimensions.....	3-1
Display .....	3-17, 7-3
Display Damping Switch.....	7-7
Display Fields .....	7-4
Display Select Switch .....	3-8
Distortion.....	1-7
Down Arrow.....	3-17
Dropouts .....	8-12
Dry Circuit Measurements.....	6-1
DTMF .....	3-9

**E**

Earphone.....	6-2
Effect of Noise .....	8-7
Effect of Nonlinear Distortion .....	8-8
End-to-End Testing .....	6-10
Envelope Delay Distortion.....	8-7
ETR/NEXT.....	3-16

AM-48 Test Set	(18-0015)	Index
ETR/PREV .....		3-16
Explanation and Application of Measurements .....		8-1
<b>F</b>		
Far End .....		8-4
Figure Format.....		7-4
Filter Select Switch .....		3-9
Front Panel/Switches Color Coding .....		3-2
Functional Overview .....		1-3
<b>G</b>		
Gain Hits.....		8-12
Gain Slope.....		8-8
General .....	3-1, 4-1, 5-1, 6-1	
General Description.....		1-2
General Instructions and Notes .....		7-3
General Instructions and Notes for MEASURE Modes.....		7-22
General Operating Notes .....		7-3
General Procedure to Set New Parameter Values.....		7-12
General Switch Setup.....	5-3, 7-6	
General Switch Setup for Self Test.....		5-3
Glossary.....		11-1
<b>H</b>		
Hand-Held Printer.....		3-20
Hand-Held Printer, External View.....		3-22
Hand-Held Printer, Internal View.....		3-23
Holding.....		1-5
Holding Tone .....		8-5

Holding Tone Ranges ..... 7-25

## I

Idle Channel Impulse Noise ..... 8-9

Idle Channel Noise ..... 8-4

Impedance Adapter ..... 3-24, 6-9

Impedance Adapter Correction Value Memory Aid ..... 7-58

Impedance Adapter Correction Values ..... 7-57

Impedance Adapter Measurement Corrections ..... 7-56

Impedance Adapter Schematic ..... 9-3

Impedances ..... 1-5

IMPLS MEASURE Displays ..... 7-32

Impulse Noise ..... 1-9

Impulse Noise Thresholds and Blanking Intervals ..... 8-10

Independent Send and Measure Modes ..... 6-2

Information Table ..... 7-5

Inspection when Received ..... 2-1

Introduction ..... 1-1, 2-1, 3-1, 6-1, 7-1, 8-1, 9-1

## K

Keyboard ..... 3-14

Keys ..... 7-3

Keys with Two (2) Auxiliary Functions ..... 7-8

## L

L/F, NOISE, and PAR MEASURE Displays ..... 7-28

Level (Loss of Gain) and Frequency ..... 8-4

Level and Noise Units of Measurement ..... 8-2

Level Display ..... 7-10

AM-48 Test Set	(18-0015)	Index
Level/Freq.....		1-8
Line Connection Cables .....		6-3
Listen .....		7-45
Loopback Testing.....		6-11
Low-Level Noise Measurements.....		4-1, 6-1

## M

Main Display Field.....		3-17
Manual Overview.....		1-1
Measure Amplitude Jitter.....		7-35
Measure Dropouts.....		7-38
Measure Gain Hits .....		7-37
Measure Impulse Noise.....		7-29
Measure Level and Frequency .....		7-27
MEASURE Modes.....		7-27
Measure Noise.....		7-28
Measure Notched Impulse Noise.....		7-36
Measure Notched Noise .....		7-32
Measure PAR.....		7-29
Measure Phase Hits .....		7-37
Measure Phase Jitter.....		7-34
MEASURE Printouts, Absolute Measure Mode .....		7-54
MEASURE Printouts, Relative Measure Mode .....		7-55
Measure S/N Ratio.....		7-34
Measure Select Switch .....		3-9
Measure Transients .....		7-36
Measurements .....		1-5
Memory .....		7-9
Memory Aid .....		7-57

Index	(18-0015)	AM-48 Test Set
Menu Color Coding and Framing .....		3-18
Menu Framing.....		7-25
Menus.....		3-18
MF.....		3-9
MF and DTMF Tone Pairs.....		7-44
Microphone/Speaker.....		3-19
Miscellaneous Operations.....		7-40
Momentary Tone .....		7-14
MON RCV .....		3-13
MON SND .....		3-13
Multi-Function Keyboard .....		7-8
Multiple Use of Keys.....		7-8
<b>N</b>		
Near End.....		8-5
NICAD .....		4-2
NiCad Batteries .....		4-4
Noise.....		1-8
Nomenclature.....		11-1
Non-Volatile Memory.....		7-9, 7-11
NOR.....		3-10
Normal Charging Procedure.....		7-47
Notched Impulse Noise .....		8-12
Notched Noise.....		1-8
Notched Noise (Noise with Tone) .....		8-4
Notched Noise and S/N Ratio MEASURE Displays.....		7-33
Notes.....		7-5



**O**

ON HK ..... 3-12  
Operating Instructions..... 7-1  
Optional AM-48 Cables ..... 3-5

**P**

P/AR Measurements..... 8-6  
P/AR Requirements of Telephone Lines ..... 8-6  
Paper Roll Compartment ..... 3-23  
Paper Roll Installation..... 3-23, 7-45  
PAR ..... 1-7, 1-8  
Parameter Settings from 1004 Hz and  
VAR Tone Displays..... 7-18  
Parameter Settings from 3-Tone Slope and  
PAR SEND Displays ..... 7-20  
Parameter Settings from QUIET SEND Display..... 7-15  
Parameter Settings from SWEEP SEND Display..... 7-21  
Parameter Values for Send Sweep ..... 5-10  
Parameter Values Stored in Memory..... 7-9  
Phase Hits..... 8-12  
Phase Jitter ..... 1-9, 8-11  
Phase JTR and Amplitude JTR MEASURE Displays ..... 7-35  
Physical ..... 1-11  
Physical and Functional Description ..... 3-1  
Power ..... 1-11  
Power Considerations ..... 4-1  
Power Off..... 4-5  
Power On/Off Switch..... 3-7, 4-4  
PRINT ..... 3-10

Printer..... 1-6  
Printer Cables..... 6-3  
Printer Connectors..... 3-20  
Printer LEDs..... 3-20  
Printer Power ..... 3-20  
Printer Power Switch ..... 3-20  
Printer Self Test..... 7-46  
Printing..... 7-45  
Printing Mechanism..... 3-21  
PULSE ..... 3-12

**Q**

Quiet ..... 1-7  
Quiet Send Mode ..... 5-4  
Quiet Send Mode Self Test ..... 5-4

**R**

RCL/STO..... 3-10  
Recall ..... 7-41  
Recall and Store Operations ..... 7-42  
Receiving and Unpacking ..... 2-1  
REL ..... 3-8, 7-23  
Return of Unit ..... 10-2  
Ribbon Cartridge Replacement ..... 7-48  
Rocker Switches ..... 3-7

**S**

S/N Ratio ..... 1-8  
Schematic Diagram of the Impedance Adapter..... 9-4

AM-48 Test Set	(18-0015)	Index
Scroll Through Displays.....		7-12
Self-Test Instructions.....		5-1
Self-Test Setup.....		5-1
SEND.....		3-8
Send (Generator) Modes and Parameter Settings .....		7-13
Send 1004 Hz.....		5-5, 7-18
Send 1004 Hz Self Test, Displays.....		5-7
Send 1004 Hz Self Test, Switch Settings.....		5-6
Send Continuous Variable Tone.....		7-19
Send Momentary 2713 Hz Tone.....		7-22
Send Momentary Variable Tones .....		7-17
Send PAR (Peak-to-Average Ratio).....		5-7, 5-8
Send PAR Waveform.....		7-22
SEND Printouts .....		7-52
Send Quiet.....		7-14
Send Select Switch.....		3-9
Send Set of Slope Tones.....		7-19
Send Variable Sweep.....		7-20
Service Policy .....		10-1
Set Blanking Interval .....		7-17
Set Level.....		7-16
Set Parameters from Quiet Display .....		7-15
Set Time Off.....		7-16
Set Touch Tone Level.....		7-16
Set Up to 10 Frequencies.....		7-16
Setup Requirements for Dialing .....		7-44
Setup Requirements for Different Keyboard Applications ..		7-8
SF Skip.....		1-7, 3-10
SHIFT .....		3-9

Signal-to-Noise (S/N) Ratio .....	8-5
Simplified Block Diagram of the AM-48 .....	9-2
Slide Switches.....	3-7
Speaker Control.....	3-13
Special Measurement Requirements.....	7-24, 7-26
Standard AM-48 Cables .....	3-4
START .....	3-17
Steps for Up and Down Arrow Keys.....	7-9
STOP.....	3-17
Store.....	7-41
Store and Recall.....	7-40
Store/Recall .....	1-6, 7-10
Sweep.....	1-7
Switch 11 Settings.....	6-8
Switch 13 Settings.....	6-8
Switch Settings.....	7-5
Switches.....	3-5
<b>T</b>	
Talk.....	1-5, 3-13, 7-45
Talking .....	7-45
TERM .....	3-12, 6-8
Term/Bridge .....	1-10
Testing Configurations.....	1-4
Testing with Responders.....	6-12
Thumb Wheel.....	3-7
Timed Tests .....	7-26
TONE.....	3-11
TRANS MEASURE Displays .....	7-39, 7-40

AM-48 Test Set	(18-0015)	Index
Transient Measurements.....		1-5
Transients.....		1-9, 1-10
Transmission Test Set.....		1-2
Types of Send Signals.....		7-13
<b>U</b>		
Units of Measurement.....		8-1
Up Arrow.....		3-17
User-Programmable Parameter Values Stored in Memory.....		7-11
<b>V</b>		
Variable.....		1-6
Verification of Contents.....		2-1
Volatile Memory.....		7-9, 7-11
Voltage to dB Conversion.....		8-3
Volume Control.....		3-13
<b>W</b>		
Warranty.....		10-1
Warranty, Service, and Calibration.....		10-1
<b>X</b>		
X TONE.....		3-10

Index

(18-0015)

AM-48 Test Set



**Ameritec is dedicated to serving the worldwide telecommunications community by providing competitively priced, state-of-the-art test equipment that is supported by the finest in marketing, engineering development and customer service.**

**Ameritec**  
**CORPORATION**

---

---

750 Arrow Grand Circle  
Covina, CA 91722 USA  
TEL (626) 915-5441  
FAX (626) 915-7181  
[www.ameritec.com](http://www.ameritec.com)  
[info@ameritec.com](mailto:info@ameritec.com)

We made our name with  
American Technology

ISO 9001 Certified Company